

GENERAL REFERENCE

SNOWDOGG LIGHT REFERENCE

GENERAL REFERENCE	3
TROUBLESHOOTING GUIDES/PROCEDURES	6
CONNECTOR REFERENCE	12
ADAPTER HARNESS REFERENCE (1607****)	13

GENERAL REFERENCE

Note

The SnowDogg lighting circuit is complete separately from the controller circuit. Any references to wire colors are specific to the relay harness. The controller does not need to be installed or powered for normal light operation.

With any troubleshooting it is easiest to reduce the normal of components being checked at any one time. To maintain the ground circuit to the truck headlight harness, you must keep the "short" leg of the relay harness attached. This is the leg with the LIGHT GRAY wire.

Method of Operation for STANDARD SWITCHED VEHICLES

Headlights

The SnowDogg relay module diverts power for the plow high and low beams from the truck harness to the snowplow lights when **the plow is connected** and the **Orange wire is energized** (connected to acc power through the red/white wire). As the power is simply diverted, there is no additional draw from the plow lights. Connecting the plow completes the ground circuit for the headlight relay coils, causing them to shift, diverting power. The relay ground circuit starts at the headlight relays, goes out through the grill connector, to the plow, back through the grill connector, and into the vehicle headlight circuit ground (gray wire).

When the plow is disconnected the ground circuit is broken, and the relays de-energize, allowing power to flow through the relay common to normally closed contacts to the truck headlights. If the orange wire is disconnected or loses power, the relays will also de-energize.

NOTE: *If the orange or red/white wire is hooked straight to a battery +12V, it will draw current at all times, draining the battery.*

Turn Signals

The purple turn signal wires in the headlight adapters (1607****) are tapped into the truck turn signal circuit, and are ONLY used to energize the turn signal relays, which draw minimal current, and should not disrupt the truck lighting circuit. The plow turn signal bulbs are powered by the orange wire (connected to the red/white wire) and are grounded with the headlights. The turn signal relays are grounded separately from the headlight relays via black wire (ground).

Parking Lights

The plow parking lights are tapped directly into the truck parking light circuit, and are not isolated. The brown wire that taps into the vehicle parking light wire is directly connected to the plow parking light. It is grounded through the vehicle headlight harness. This is an excellent place to start when troubleshooting.

GENERAL REFERENCE

Method of Operation for GROUND SWITCHED VEHICLES

Headlights

The SnowDogg relay module diverts the switched ground path for the plow high and low beams from the truck harness to the snowplow lights when the plow is connected and the Gray wire is energized (connected to the red/white wire), typically from an ACC source (only on when the ignition is on). Connecting the plow completes the power circuit for the headlight relays, causing them to shift, diverting the switched ground circuit. In a switched ground vehicle, the common circuit is +12V.

When the plow is disconnected or the gray wire is not powered, the power circuit is broken, and the headlight ground current flows through the relay common to normally closed contacts to the truck headlights.

NOTE: *If the gray or red/white wire is hooked straight to a battery +12V, it will draw current at all times, draining the battery.*

Turn Signals

The purple turn signal wires on the headlight adapters (1607****) are tapped into the truck turn signal circuit, and are ONLY used to energize the turn signal relays, which draw minimal current, and should not disrupt the truck lighting circuit. These relays connect the switched leg of the plow turn signals to ground when energized. The turn signal bulbs are powered by the +12V common (black wire at the plow headlights).

Parking Lights

The brown wires for the plow parking lights are connected to vehicle ground – NOT TO THE VEHICLE PARKING CIRCUIT. The plow parking lights are powered by the +12V common (black wire at the plow headlights). **If the brown wires are incorrectly connected to the vehicle parking light circuit, they will only work when the vehicle is turned on, but the ignition is off. When the ignition is turned on, the plow parking lights will turn off.**

GENERAL REFERENCE

Proper Operation of Lights

Plow Parking lights

On simultaneously with the Truck Parking Lights. For SWITCHED GROUND vehicles the parking lights will be on whenever the vehicle ignition is on, regardless of the vehicle parking light status.

Plow Turn Signals

On simultaneously with the Truck Turn signals / isolated by relays

Plow Headlights

On INSTEAD of Truck headlights. Truck and Plow headlights should NEVER be on at the same time.

GENERAL REFERENCE

NOTE:

MOST light malfunctions are due to installation problems. Before beginning any extensive troubleshooting, check the www.snowdogplows.com website for updated installation instructions and technical service bulletins. Review the instructions for your specific application and verify that all instructions have been followed.

Contact your dealer promptly for technical assistance – all lighting issues can usually be resolved very quickly, and those that can't are usually due to an issue with the vehicle side circuit.

Always verify that ALL light circuits on the vehicle are working properly before beginning plow installation. Aftermarket accessories like Remote Starters, HID kits, non-factory headlights, existing plow installations, can cause an installation to fail. It may be necessary to remove aftermarket components to ensure the proper operation of the plow lights.

Symptom	Cause	Resolution
Truck lights do not behave properly after plow is installed on truck	Headlight adapter or relay harness is incorrectly installed or faulty	Check installation
Plow lights deactivate when high beams are selected	Polarity on connection between headlight adapter and vehicle harness is reversed.	Verify application Contact Tech Support
Parking lights turn off when plow headlights are activated	Brown wires on headlight adapters are connected to wrong location.	Standard vehicles – brown wire to parking circuit. Switched ground vehicles – brown wire to GROUND
Plow headlights are on at the same time as truck headlights	Headlight adapter or relay harness is incorrectly installed or faulty	Check installation
Plow lights do not activate when plow is connected	Ground circuit through headlight adapter is wrong.	Verify polarity of headlight adapters
	Orange wire is not at +12V	Check Installation

GENERAL REFERENCE

	A headlight relay coil is shorted	Replace faulty relay
Fuses blow when lights are activated	There is a short to ground in the circuit	Verify all harnesses
	Vehicle draws excessive current (>10A)	Replace in-line fuse with 15A fuse
High and Low Beams are on at the same time	Truck has "dual burn" hi/low beams (2007+ GM)	Works as Designed
Lights on one side of vehicle are behaving differently than other side (dim, off, etc.)	Headlight adapter harness is installed incorrectly	Verify installation or Replace
	Vehicle side fuse is blown	Check/Replace Fuses
Truck lights do not reactivate when plow is disconnected	Light circuit is grounding incorrectly	Contact SnowDogg tech support
A single light is not working (left low beam, right parking, etc.)	The bulb is defective	Replace
	A harness has an open circuit	Repair/Replace
	If truck remains on - the relay controlling that bulb is malfunctioning	Replace
Parking lights and Turn signals do not operate on the plow when headlights are off	Headlight harness is not installed correctly	Verify Installation

GENERAL REFERENCE

	Ambient light sensor is disabling power to plow lights	Verify Installation
Plow lights remain on when the truck is off	Installation is incorrect for the vehicle application	Verify Installation
Battery is being drained when truck is off	Red/White wire is not connected to a switched circuit	Connect to a switched circuit
	Installation is incorrect	Verify Installation

GENERAL REFERENCE

These instructions are written for STANDARD switched vehicles only. Contact technical support for assistance with GROUND switched vehicles.

Relay Module Activation Troubleshooting

1. **Disconnect the plow light harness from the truck light harness (unplug the large overmolded connector)**
2. **Turn the truck parking lights on**
3. **Check for continuity between pin A and chassis ground or headlight ground**
 - If there is continuity
 - Continue*
 - If there is no continuity –
 - Disconnect the headlight adapter*
 - Check for continuity between pin A on the overmold connector and pin B on the headlight adapter connector.*
 - If there is continuity
 - Continue*
 - If there is no continuity
 - The gray wire has a continuity break and must be repaired.*
4. **Check for +12V on pins G+J, using pin A as ground**
 - If +12V IS present
 - Park lights on plow should functional normally*
 - If +12V IS NOT present
 - One of the two brown wires has a continuity break and must be repaired*
5. **Measure resistance between pin H and the orange wire. It should be between 20 and 25 ohms.**
 - If the resistance is nearly zero
 - A relay is defective and must be replaced. Remove each relay and check resistance across the coil to find the faulty relay.*
 - If the resistance is within acceptable limits
 - Continue*
6. **Ensure that the cab switch is on (if used)**
7. **Check for +12V on the orange wire**
 - If voltage is present
 - Contact SnowDogg tech support*
 - If voltage is not present

GENERAL REFERENCE

Check the power supply to the orange wire – this should be connected to an accessory circuit.

Relay Module Headlight Circuit Troubleshooting

1. Turn on truck low beam headlights
2. Jumper pins A and H together – this will simulate the plow being connected
You should hear the relays click at this point, and truck lights should turn off. If the relay module begins to buzz, than the ground circuit is faulty – see TS1 and TS2
3. Check for +12V at pins B and D (Low Beams) on grill headlight connector
 - a. If +12V IS present
 - i. Continue
 - b. If +12V IS NOT present
 - i. Check for +12V at pin C of the adapter connector (YELLOW)
 1. If +12V IS present
 - a. *The headlight adapter is defective – repair/replace*
 2. If +12V IS NOT present
 - a. *The relay harness is faulty – repair/replace*
 4. Switch the truck lights to high beams
 5. Check for +12V at pins C and E (High Beams)
 6. If +12V IS present
 - i. Continue
 7. If +12V IS NOT present
 - i. Check for +12V at pin F of the adapter connector (GREEN)
 1. If +12V IS present
 - a. *The relay harness is defective – repair/replace*
 2. If +12V IS NOT present
 - a. *The headlight adapter is faulty – repair/replace*

Turn Signal Troubleshooting

- 1) Activate the left turn signal
- 2) Check for voltage at pins G and K – one should be pulsing with +12V (one is Left, one is Right)
 - If +12V IS present
Continue
 - If +12V IS NOT present
Check for pulsing +12V at purple wire at position H of appropriate adapter harness connector

GENERAL REFERENCE

If voltage is present

The relay harness is defective – repair/replace

If voltage is not present and vehicle turn signals work properly

Check the connection of the purple wire – it should be spliced into the vehicle turn signal wire.

3) Activate the right turn signal and repeat above procedure

Plow Light/Plow Light Harness Troubleshooting

1) Connect the Plow Light Harness to the Relay Harness.

2) Check operation of all lights

Headlight not functioning properly?

Disconnect both headlights – set aside working headlight

Connect faulty headlight to OTHER harness lead

Still faulty?

Headlight is defective – repair/replace

Works OK

Wiring harness is faulty – repair/replace

Power Draw Troubleshooting

1) Connect the Plow Light Harness to the Relay Harness and turn on vehicle.

2) Check for proper operation of all lights

Working properly

Continue

NOT working properly

STOP – see TS1-TS5

3) Turn vehicle off

4) Connect Plow

If any lights on the plow are on

Lighting installation is incorrect – STOP – see TS1-TS5

All lights off

Continue

5) Install a clamp on ammeter on the main battery connection and measure current draw with the plow connected AND disconnected

Draw is the same

The vehicle OEM harness has a defect – STOP

GENERAL REFERENCE

Draw with plow connected is higher

Continue

6) Place clamp on ammeter on Orange wire

If current draw is >0

Disconnect Orange wire

Measure resistance between Orange wire and battery ground

If resistance is <20 ohms

Relay harness is faulty – repair/replace

If resistance is between 20 and 25 ohms

Contact SnowDogg tech support

If current draw is 0

Continue

7) Place clamp on ammeter on Red Wire

If current draw is >0

Disconnect red wire

Measure resistance between Red wire and battery ground

If resistance is <40 ohms

Relay Harness is faulty – repair/replace

If resistance is between 40-50 ohms

Disconnect Purple wires from vehicle turn signal wires on both sides of the vehicle

If current draw on Red wire is still >0

The Relay Harness is faulty – repair/replace

If current draw on Red wire is 0

Contact SnowDogg tech support

If current draw is 0

Continue

8) Disconnect Headlight Adapters (1607****) on both sides of vehicle

If current draw is >0

Contact SnowDogg Tech Support

If current draw is 0

Headlight adapters are faulty – repair/replace

HARNES REFERENCE

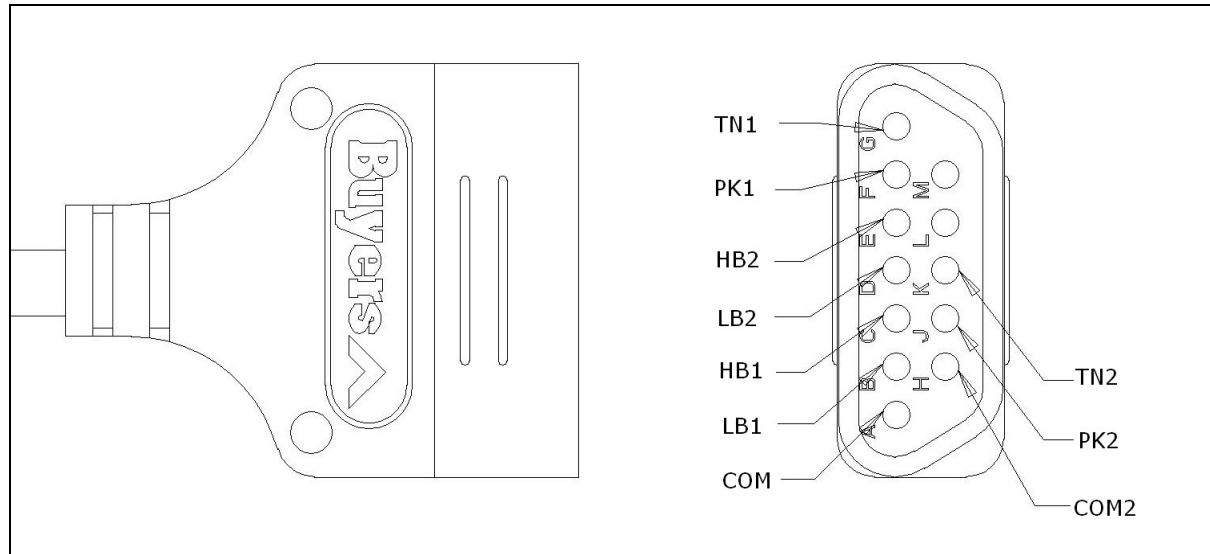

Relay Harness Connector to Plow Light Harness (TRUCK SIDE)

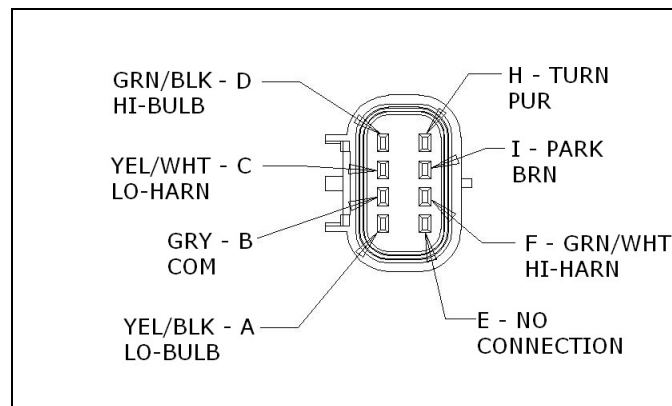

Relay Harness Connector to Headlight Adapter
B (COM) pin is only present on "short" leg
RELAY HARNESS SIDE

16071050 UNIVERSAL SPLICE KIT

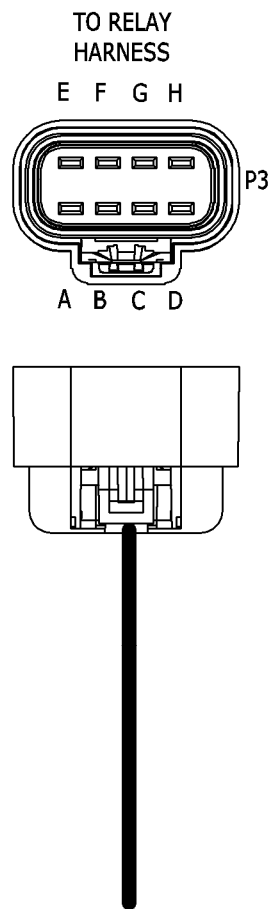

FUNCTION	P3 PIN	WIRE COLOR	RELAY HARNESS
LIGHT LB	A	YEL/BLK	YEL/BLK
COMMON	B	BLK	GRAY*
HARNESS LB	C	YEL	YEL/WHT
LIGHT HB	D	GRN/BLK	GRN/BLK
-	E	-	-
HARNESS HB	F	GRN	GRN/WHT
PARK	G	BROWN	BROWN
TURN	H	PURPLE	PURPLE

* ONLY PRESENT ON SHORT
RELAY HARNESS LEAD

HARNESS REFERENCE

16071100
H13

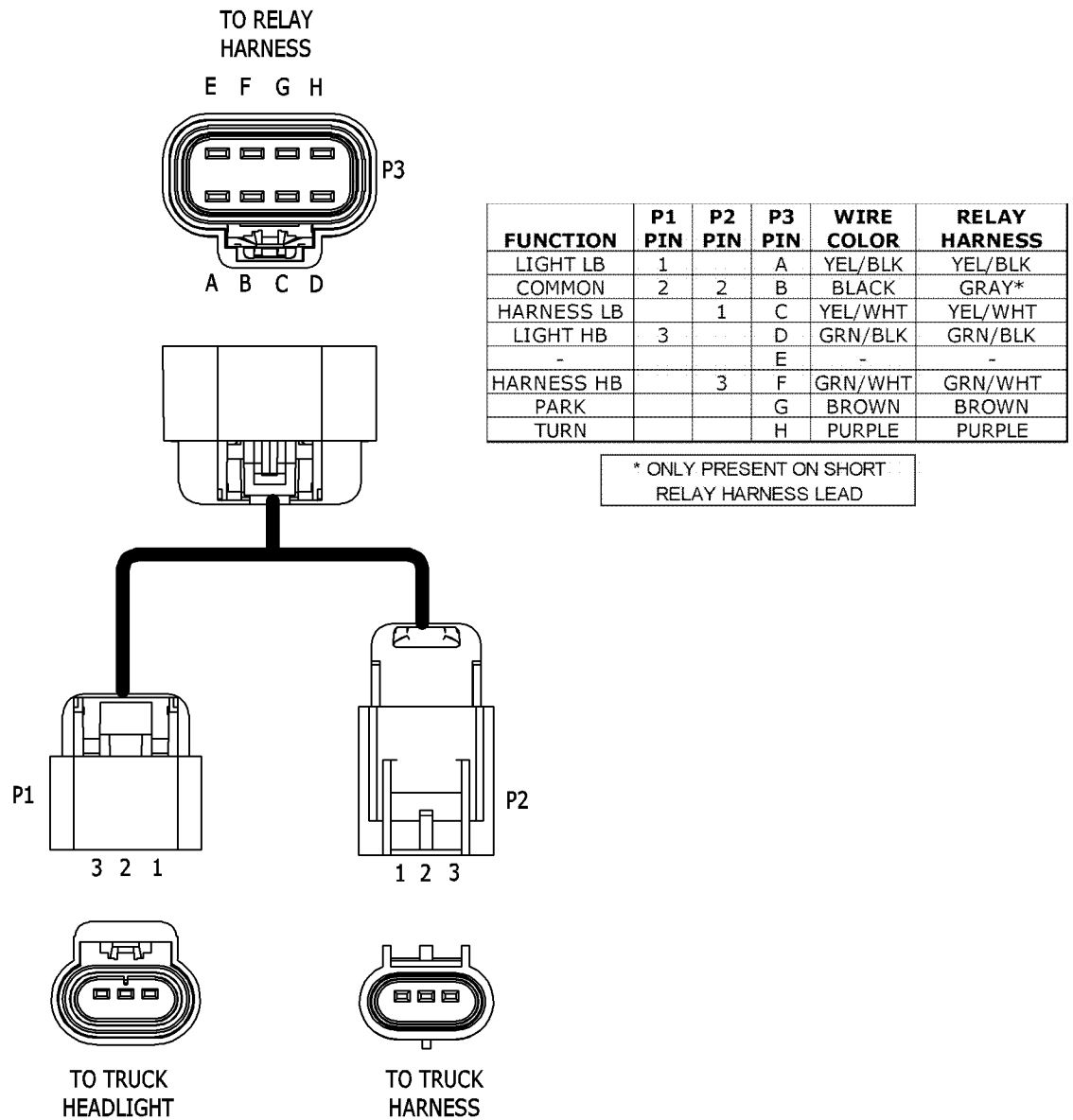

HARNESS REFERENCE

16071110
GM 2007+ BREAKOUT

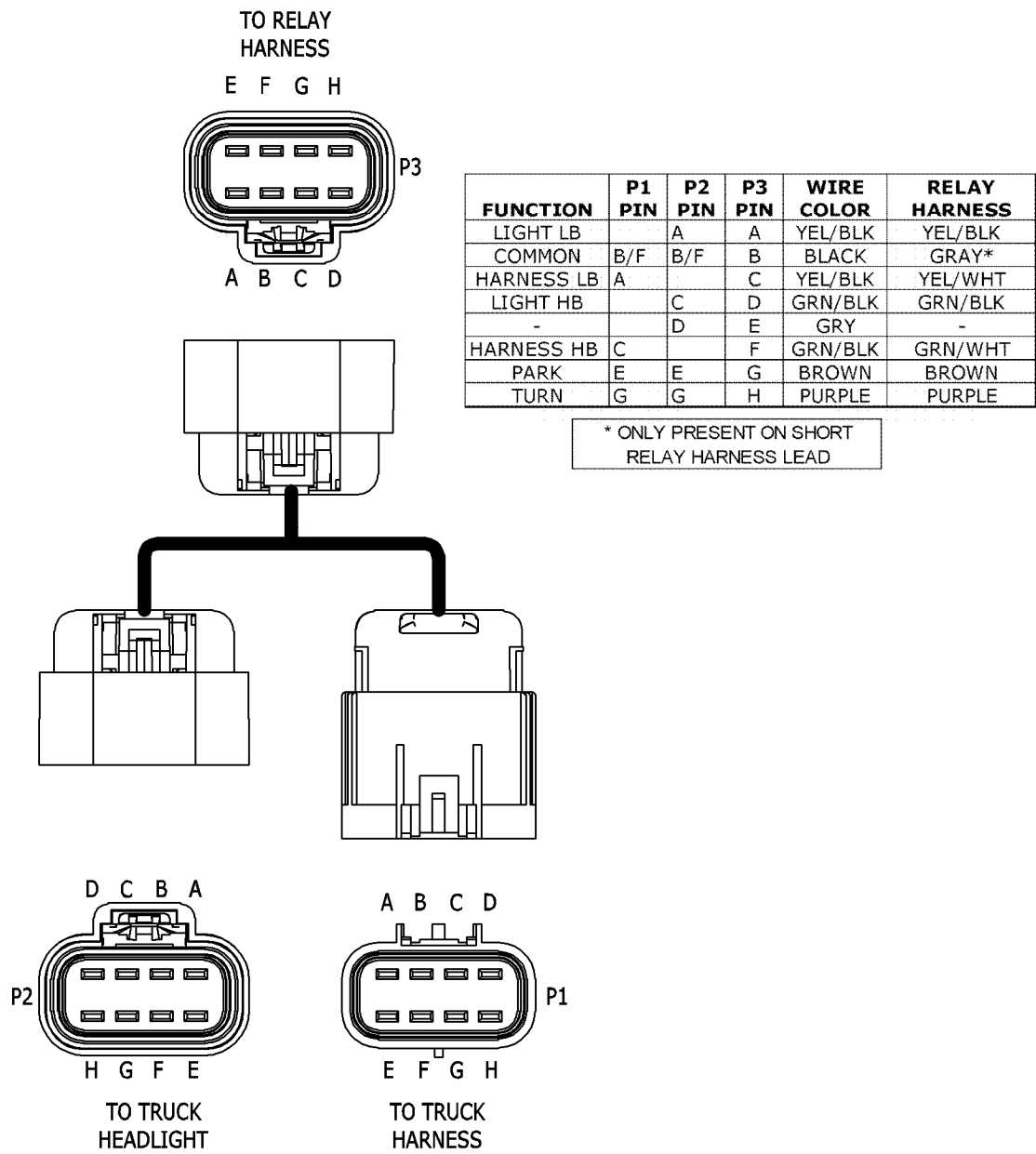

HARNES REFERENCE

16071120
HB5

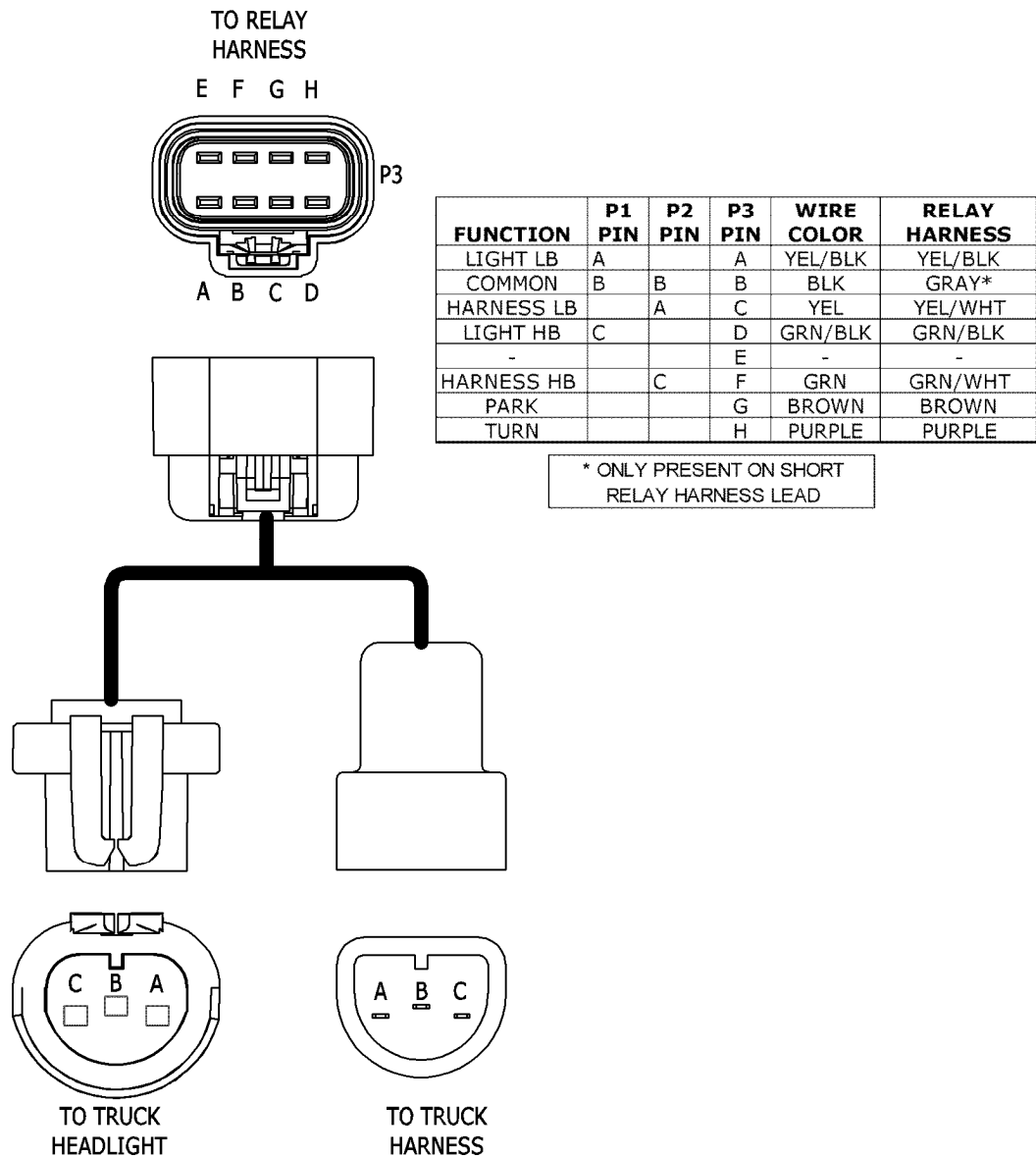

HARNES REFERENCE

16071130
HB1

TO RELAY
HARNES
E F G H

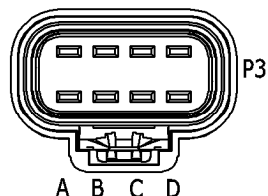

FUNCTION	P1 PIN	P2 PIN	P3 PIN	WIRE COLOR	RELAY HARNES
LIGHT LB	B		A	BLK	YEL/BLK
COMMON	A	A	B	YEL/BLK	GRAY*
HARNES LB		B	C	BLK	YEL/WHT
LIGHT HB	C		D	GRN/BLK	GRN/BLK
-			E	-	-
HARNES HB		C	F	GRN	GRN/WHT
PARK			G	BROWN	BROWN
TURN			H	PURPLE	PURPLE

* ONLY PRESENT ON SHORT
RELAY HARNES LEAD

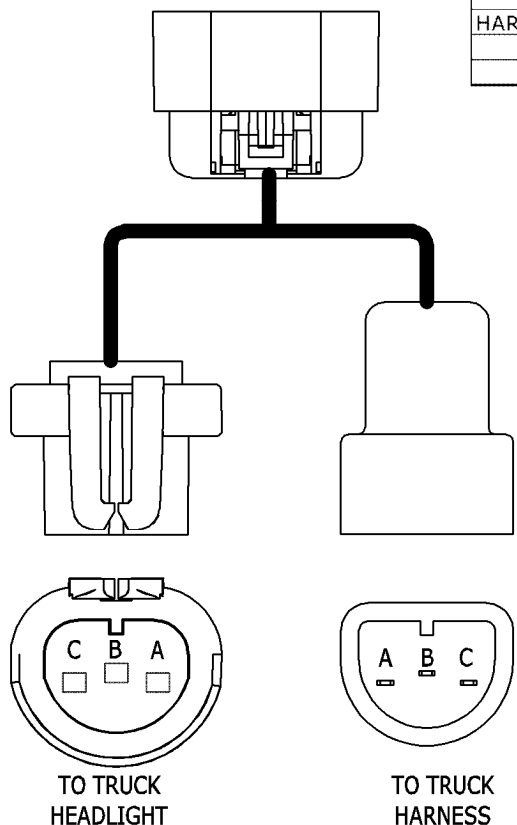

HARNES REFERENCE

16071140
HB2/2B/2D

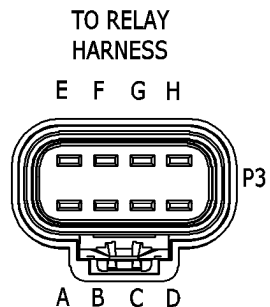

FUNCTION	P1 PIN	P2 PIN	P3 PIN	WIRE COLOR	RELAY HARNESS
LIGHT LB	B		A	BLK	YEL/BLK
COMMON	A	A	B	BLK	GRAY*
HARNESS LB		B	C	YEL	YEL/WHT
LIGHT HB	C		D	BLK	GRN/BLK
-			E	-	-
HARNESS HB		C	F	GRN	GRN/WHT
PARK			G	BROWN	BROWN
TURN			H	PURPLE	PURPLE

* ONLY PRESENT ON SHORT RELAY HARNESS LEAD

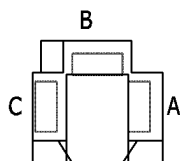
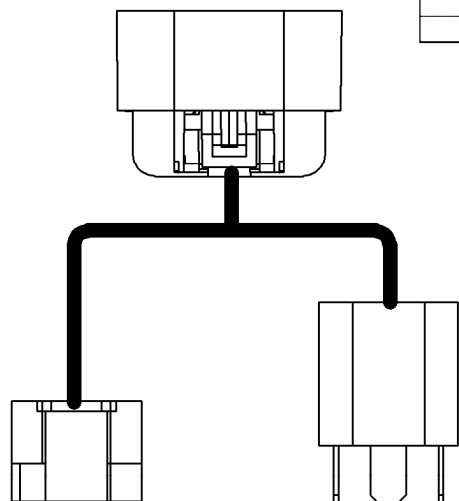

TO TRUCK HEADLIGHT

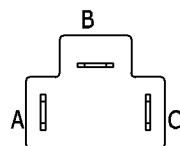

TO TRUCK HARNESS

HARNES REFERENCE

16071150
HB3/HB4

TO RELAY
HARNES

E F G H

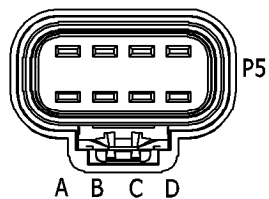

FUNCTION	P1 PIN	P2 PIN	P3 PIN	P4 PIN	P5 PIN	WIRE COLOR	RELAY HARNES
LIGHT LB	A				A	YEL	YEL/BLK
COMMON	B	B	B	B	B	BLACK	GRAY*
HARNES LB			A		C	YEL/BLK	YEL/WHT
LIGHT HB		A			D	GRN	GRN/BLK
-					E	-	-
HARNES HB				A	F	GRN/BLK	GRN/WHT
PARK					G	BROWN	BROWN
TURN					H	PURPLE	PURPLE

* ONLY PRESENT ON SHORT
RELAY HARNES LEAD

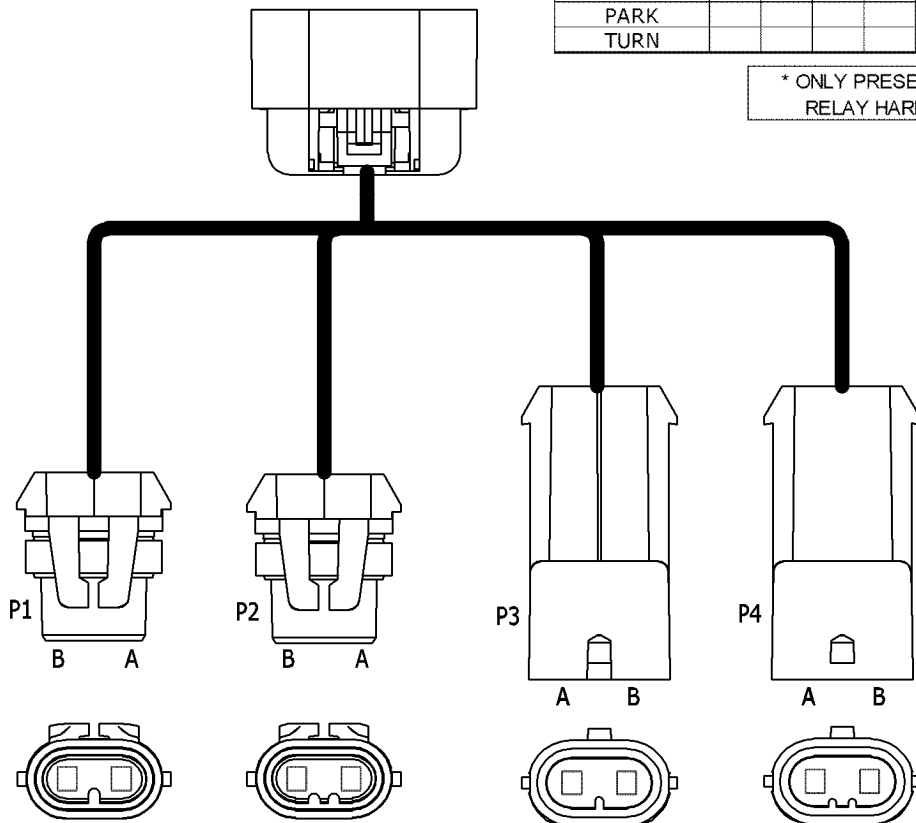

HARNESS REFERENCE

16071150R
HB3/HB4 SWITCHED GROUND

TO RELAY
HARNESS
E F G H

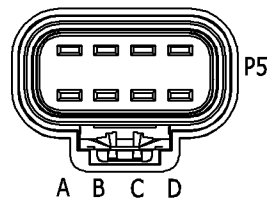

FUNCTION	P1 PIN	P2 PIN	P3 PIN	P4 PIN	P5 PIN	WIRE COLOR	RELAY HARNESS
LIGHT LB	A				A	YEL	YEL/BLK
COMMON	B	B	A	A	B	BLACK	GRAY*
HARNESS LB			B		C	YEL/BLK	YEL/WHT
LIGHT HB		A			D	GRN	GRN/BLK
-					E	-	-
HARNESS HB				B	F	GRN/BLK	GRN/WHT
PARK					G	BROWN	BROWN
TURN					H	PURPLE	PURPLE

* ONLY PRESENT ON SHORT
RELAY HARNESS LEAD

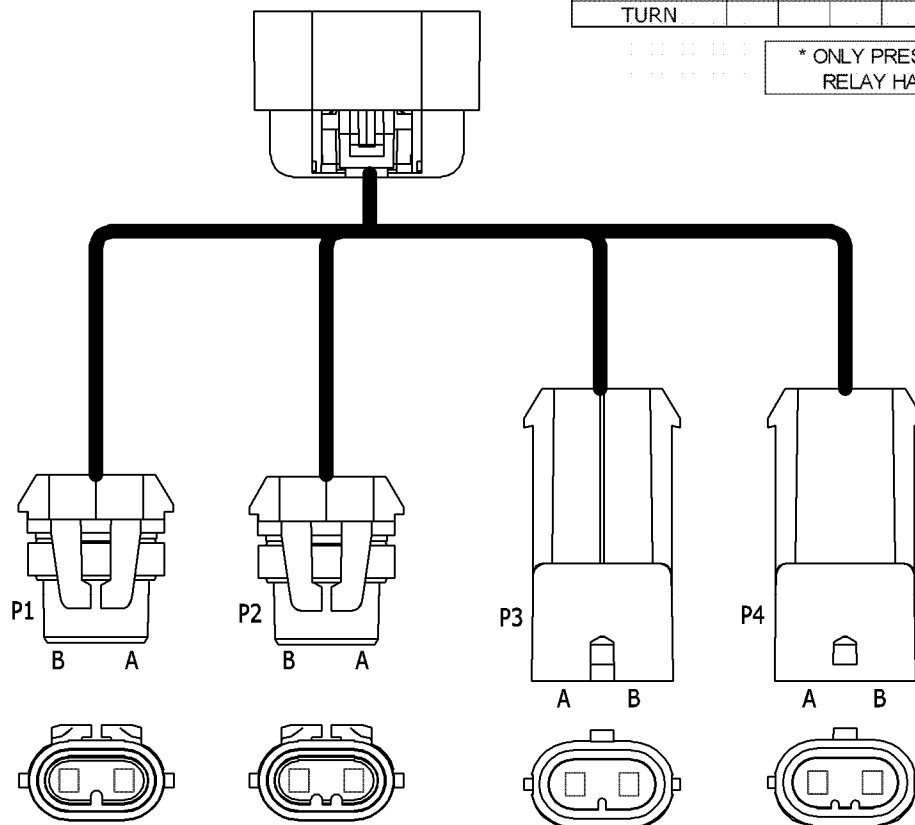

HARNES REFERENCE

16071160
HB3/H11

TO RELAY
HARNES

E F G H

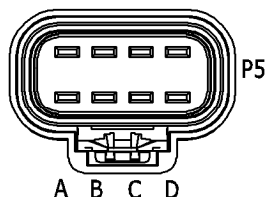

FUNCTION	P1 PIN	P2 PIN	P3 PIN	P4 PIN	P5 PIN	WIRE COLOR	RELAY HARNES
LIGHT LB	A				A	YEL	YEL/BLK
COMMON	B	B	A	A	B	BLACK	GRAY*
HARNES LB			B		C	YEL/BLK	YEL/WHT
LIGHT HB		A			D	GRN	GRN/BLK
-					E	-	-
HARNES HB				B	F	GRN/BLK	GRN/WHT
PARK					G	BROWN	BROWN
TURN					H	PURPLE	PURPLE

* ONLY PRESENT ON SHORT
RELAY HARNES LEAD

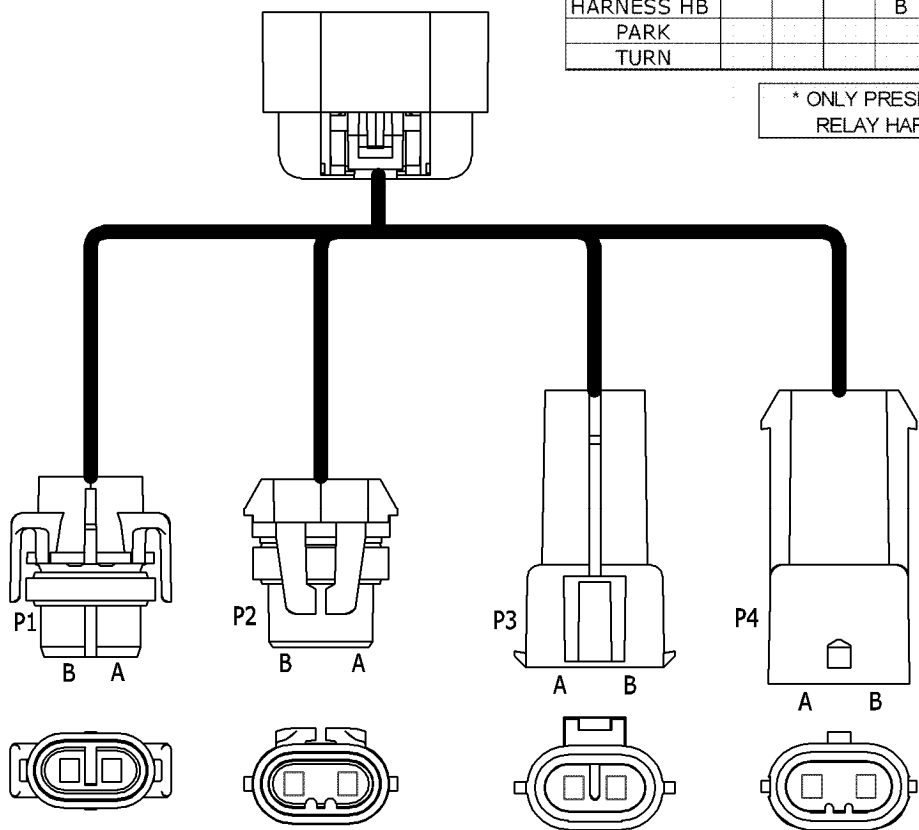

HARNESS REFERENCE

NOTES

SCHEMATIC REFERENCE
