SNOWDOGG LIGHT REFERENCE

GENERAL REFERENCE	3
TROUBLESHOOTING GUIDES/PROCEDURES	5
CONNECTOR REFERENCE	12
ADAPTER HARNESS REFERENCE (1607****)	13
SCHEMATIC REFERENCE	22

GENERAL REFERENCE

Note

The SnowDogg lighting circuit is complete separately from the controller circuit. Any references to wire colors are specific to the relay harness. The controller does not need to be installed or powered for normal light operation.

These instructions do not apply to switched ground vehicles (99-02 GM's, 04+ Colorado/Canyon, 99-02 Dodge Ram). Contact SnowDogg tech support for specific instructions for these vehicles.

With any troubleshooting it is easiest to reduce the normal of components being checked at any one time. To maintain the ground circuit to the truck headlight harness, you must keep the "short" leg of the relay harness attached. This is the leg with the LIGHT GRAY wire.

Method of Operation

Headlights

The SnowDogg relay isolation module diverts power for the plow high and low beams from the truck harness to the snowplow lights when the plow is connected, and the Orange wire is energized (+12V), typically from an ACC source (only on when the ignition is on). As the power is diverted, there is no additional draw from the plow lights.

When the plow is disconnected or the orange wire is not powered, the power flows through the relay common to normally contracts to the truck headlights.

NOTE: *If the orange wire is hooked straight to a battery +12V, it will draw current at all times, draining the battery.*

Turn Signals

The plow turn signal bulbs are powered by the red wire, and are grounded through the headlight truck harness ground (light gray wire). The truck turn signal wires (purple) are used to energize the turn signal relays, which draw minimal current, and should not disrupt the truck lighting circuit. The turn signal relays are grounded separately from the headlight relays via the blunt cut black wire.

Parking Lights

The plow parking lights are tee'd directly into the truck parking light wire, and are not isolated. The brown wire that taps into the vehicle parking light wire is directly connected to the plow parking light. It is grounded through the vehicle headlight harness.

TROUBLESHOOTING

With any troubleshooting it is easiest to reduce the normal of components being checked at any one time. To maintain the ground circuit to the truck headlight harness, you must keep the “short” leg of the relay harness attached. This is the leg with the LIGHT GRAY wire.

Proper Operation of Lights

Plow Parking lights

On simultaneously with the Truck Parking Lights

Plow Turn Signals

On simultaneously with the Truck Turn signals / isolated by relays

Plow Headlights

On INSTEAD of Truck headlights. Truck and Plow headlights should NEVER be on at the same time.

TROUBLESHOOTING

Symptom	Cause	Resolution	Tests
Truck lights do not behave properly after plow is installed on truck	Headlight adapter or relay harness is incorrectly installed or faulty	Check installation	TS1
Plow lights deactivate when high beams are selected	Polarity on connection between headlight adapter and vehicle harness is reversed.	Verify polarity of headlight adapter	TS1
Parking lights or Turn signals turn off when plow headlights are activated	Polarity on connection between headlight adapter and vehicle harness is reversed.	Verify polarity of headlight adapter	TS1
Plow headlights are on at the same time as truck headlights	Headlight adapter or relay harness is incorrectly installed or faulty	Check installation	TS1-TS5
Plow lights do not activate when plow is connected	Ground circuit through headlight adapter is wrong.	Verify polarity of headlight adapters	TS1
	Orange wire is not at +12V	Check Installation	TS2
	A headlight relay coil is shorted	Replace faulty relay	TS2
Fuses blow when lights are activated	There is a short to ground in the circuit	Verify all harnesses	TS1-TS5
High and Low Beams are on at the same time	Truck has "dual burn" hi/low beams (2007+ GM)	Works as Designed	

TROUBLESHOOTING

Lights on one side of vehicle are behaving differently than other side (dim, off, etc.)	Headlight adapter harness is installed incorrectly	Verify installation or Replace	TS3
	Relay harness is defective	Repair or Replace	
Truck lights do not reactivate when plow is disconnected	Light circuit is grounding incorrectly	Contact SnowDogg tech support	
A single light is not working (left low beam, right parking, etc.)	The bulb is defective	Replace	TS5
	A harness has an open circuit	Repair/Replace	TS3-TS5
Parking lights and Turn signals do not operate on the plow when headlights are off	Headlight harness is installed incorrectly	Verify Installation	1607**** Instructions
	Ambient light sensor is disabling power to plow lights	Verify Installation	1607**** Instructions
Plow lights remain on when the truck is off	Installation is incorrect for the vehicle application	Verify Installation	1607**** Instructions
Battery is being drained when truck is off	Orange wire is not connected to a switched circuit	Connect to a switched circuit	Owner's Manual
	Installation is incorrect	Verify Installation	TS6

TROUBLESHOOTING

TS1 Headlight Harness Polarity Check – positive switched vehicles only

1. Turn the truck LOW beam headlights on – plow does not need to be connected
2. Check for +12V at the YELLOW wire on the headlight adapter (1607****) that interfaces with the vehicle headlight harness. This should also be position C on the 8-position relay module connector.

If +12V IS present

Continue

If +12V IS NOT present

Headlight adapter polarity is incorrect

Swap A+B pins on headlight connector or contact SnowDogg tech support

3. Turn the truck HIGH beam headlights on – plow does not need to be connected
4. Check for +12V at the GREEN wire on the headlight adapter (1607****) that interfaces with the vehicle headlight harness. This should also be position D on the 8-position relay module connector.

If +12V IS present

Continue

If +12V IS NOT present

Headlight adapter polarity is incorrect

Swap A+B pins on headlight connector or contact SnowDogg tech support

5. Check for ground at the BLACK wire on the headlight adapter (1607****) that interfaces with the vehicle headlight harness. This should also be position B on the 8-position relay module connector.

If wire is grounded

Continue

If wire is NOT grounded

Headlight adapter polarity is incorrect

Swap A+B pins on headlight connector or contact SnowDogg tech support

TS2 Relay Module Activation Troubleshooting

1. Disconnect the plow light harness from the truck light harness (unplug the large overmolded connector)
2. Turn the truck parking lights on
3. Check for continuity between pin A and chassis ground or headlight ground

If there is continuity

Continue

If there is no continuity –

TROUBLESHOOTING

Disconnect the headlight adapter

Check for continuity between pin A on the overmold connector and pin B on the headlight adapter connector.

If there is continuity

Continue

If there is no continuity

The gray wire has a continuity break and must be repaired.

4. Check for +12V on pins G+J, using pin A as ground

If +12V IS present

Park lights on plow should functional normally

If +12V IS NOT present

One of the two brown wires has a continuity break and must be repaired

5. Measure resistance between pin H and the orange wire. It should be between 20 and 25 ohms.

If the resistance is nearly zero

A relay is defective and must be replaced. Remove each relay and check resistance across the coil to find the faulty relay.

If the resistance is within acceptable limits

Continue

6. Ensure that the cab switch is on (if used)

7. Check for +12V on the orange wire

If voltage is present

Contact SnowDogg tech support

If voltage is not present

Check the power supply to the orange wire – this should be connected to an accessory circuit.

TS3 Relay Module Headlight Circuit Troubleshooting

1. Turn on truck lowbeam headlights

2. Jumper pins A and H together – this will simulate the plow being connected

You should hear the relays click at this point, and truck lights should turn off. If the relay module begins to buzz, than the ground circuit is faulty – see TS1 and TS2

3. Check for +12V at pins B and D (Low Beams) on grill headlight connector

a. *If +12V IS present*

i. Continue

b. *If +12V IS NOT present*

TROUBLESHOOTING

- i. Check for +12V at pin C of the adapter connector (YELLOW)
 1. If +12V IS present
 - a. *The headlight adapter is defective – repair/replace*
 2. If +12V IS NOT present
 - a. *The relay harness is faulty – repair/replace*
- 4. Switch the truck lights to high beams**
- 5. Check for +12V at pins C and E (High Beams)**
- 6. If +12V IS present**
 - i. *Continue*
- 7. If +12V IS NOT present**
 - i. Check for +12V at pin F of the adapter connector (GREEN)
 1. If +12V IS present
 - a. *The relay harness is defective – repair/replace*
 2. If +12V IS NOT present
 - a. *The headlight adapter is faulty – repair/replace*

TS4 Turn Signal Troubleshooting

- 1) Activate the left turn signal**
- 2) Check for voltage at pins G and K – one should be pulsing with +12V (one is Left, one is Right)**
 - If +12V IS present
 - Continue*
 - If +12V IS NOT present
 - Check for pulsing +12V at purple wire at position H of appropriate adapter harness connector*
 - If voltage is present
 - The relay harness is defective – repair/replace*
 - If voltage is not present and vehicle turn signals work properly
 - Check the connection of the purple wire – it should be spliced into the vehicle turn signal wire.*
- 3) Activate the right turn signal and repeat above procedure**

TS5 Plow Light/Plow Light Harness Troubleshooting

- 1) Connect the Plow Light Harness to the Relay Harness.**
- 2) Check operation of all lights**
 - Headlight not functioning properly?
 - Disconnect both headlights – set aside working headlight*

TROUBLESHOOTING

Connect faulty headlight to OTHER harness lead

Still faulty?

Headlight is defective – repair/replace

Works OK

Wiring harness is faulty –repair/replace

TS6 Power Draw Troubleshooting

1) Connect the Plow Light Harness to the Relay Harness and turn on vehicle.

2) Check for proper operation of all lights

Working properly

Continue

NOT working properly

STOP – see TS1-TS5

3) Turn vehicle off

4) Connect Plow

If any lights on the plow are on

Lighting installation is incorrect – STOP – see TS1-TS5

All lights off

Continue

5) Install a clamp on ammeter on the main battery connection and measure current draw with the plow connected AND disconnected

Draw is the same

The vehicle OEM harness has a defect – STOP

Draw with plow connected is higher

Continue

6) Place clamp on ammeter on Orange wire

If current draw is >0

Disconnect Orange wire

Measure resistance between Orange wire and battery ground

If resistance is <20 ohms

Relay harness is faulty – repair/replace

If resistance is between 20 and 25 ohms

Contact SnowDogg tech support

If current draw is 0

TROUBLESHOOTING

Continue

7) Place clamp on ammeter on Red Wire

If current draw is >0

Disconnect red wire

Measure resistance between Red wire and battery ground

If resistance is <40 ohms

Relay Harness is faulty – repair/replace

If resistance is between 40-50 ohms

Disconnect Purple wires from vehicle turn signal wires on both sides of the vehicle

If current draw on Red wire is still >0

The Relay Harness is faulty – repair/replace

If current draw on Red wire is 0

Contact SnowDogg tech support

If current draw is 0

Continue

8) Disconnect Headlight Adapters (1607**) on both sides of vehicle**

If current draw is >0

Contact SnowDogg Tech Support

If current draw is 0

Headlight adapters are faulty – repair/replace

SCHEMATIC REFERENCE

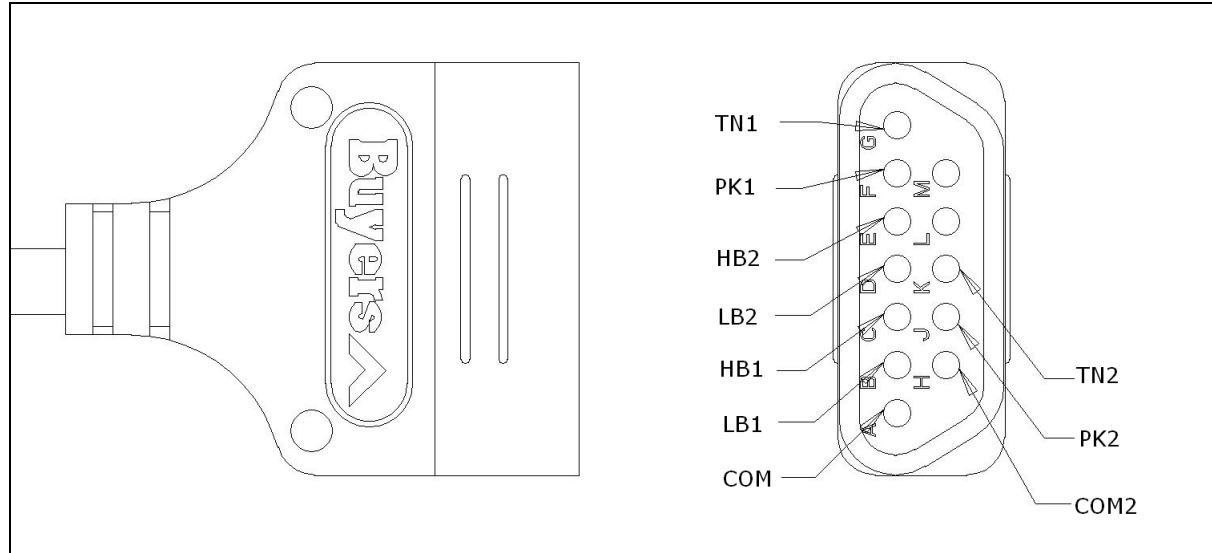

Relay Harness Connector to Plow Light Harness (TRUCK SIDE)

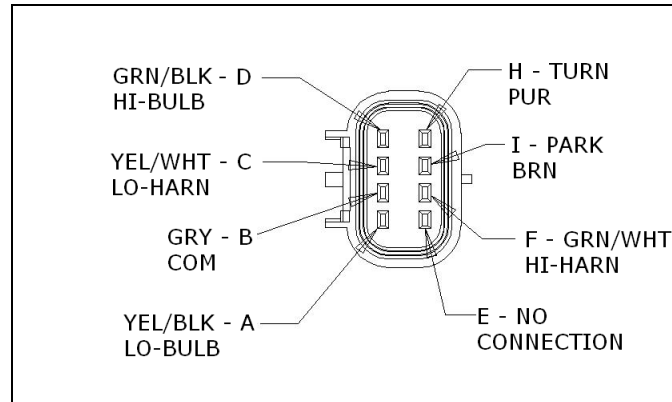

**Relay Harness Connector to Headlight Adapter
B (COM) pin is only present on "short" leg
RELAY HARNESS SIDE**

16071050 UNIVERSAL SPLICE KIT

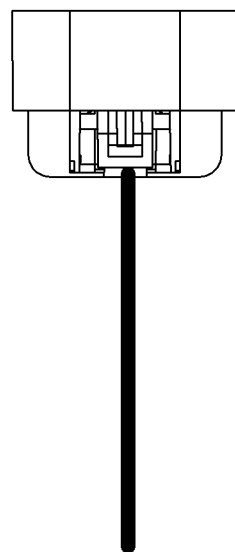
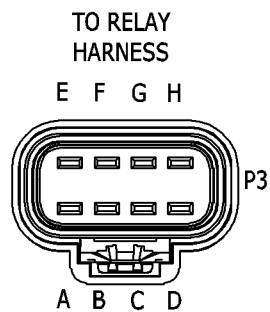

FUNCTION	P3 PIN	WIRE COLOR	RELAY HARNESS
LIGHT LB	A	YEL/BLK	YEL/BLK
COMMON	B	BLK	GRAY*
HARNESS LB	C	YEL	YEL/WHT
LIGHT HB	D	GRN/BLK	GRN/BLK
-	E	-	-
HARNESS HB	F	GRN	GRN/WHT
PARK	G	BROWN	BROWN
TURN	H	PURPLE	PURPLE

* ONLY PRESENT ON SHORT
RELAY HARNESS LEAD

HARNESS REFERENCE

16071100
H13

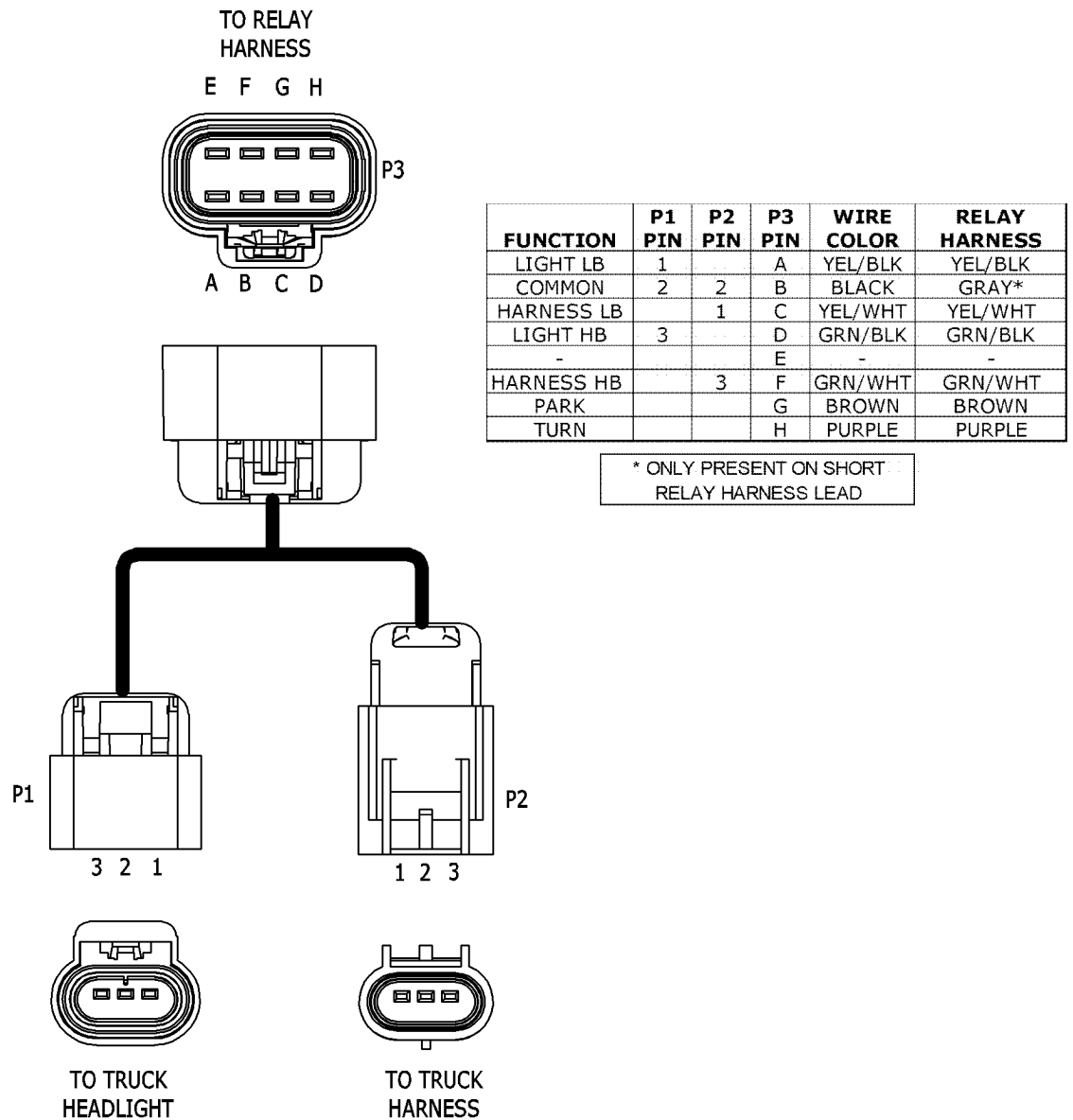

16071110
GM 2007+ BREAKOUT

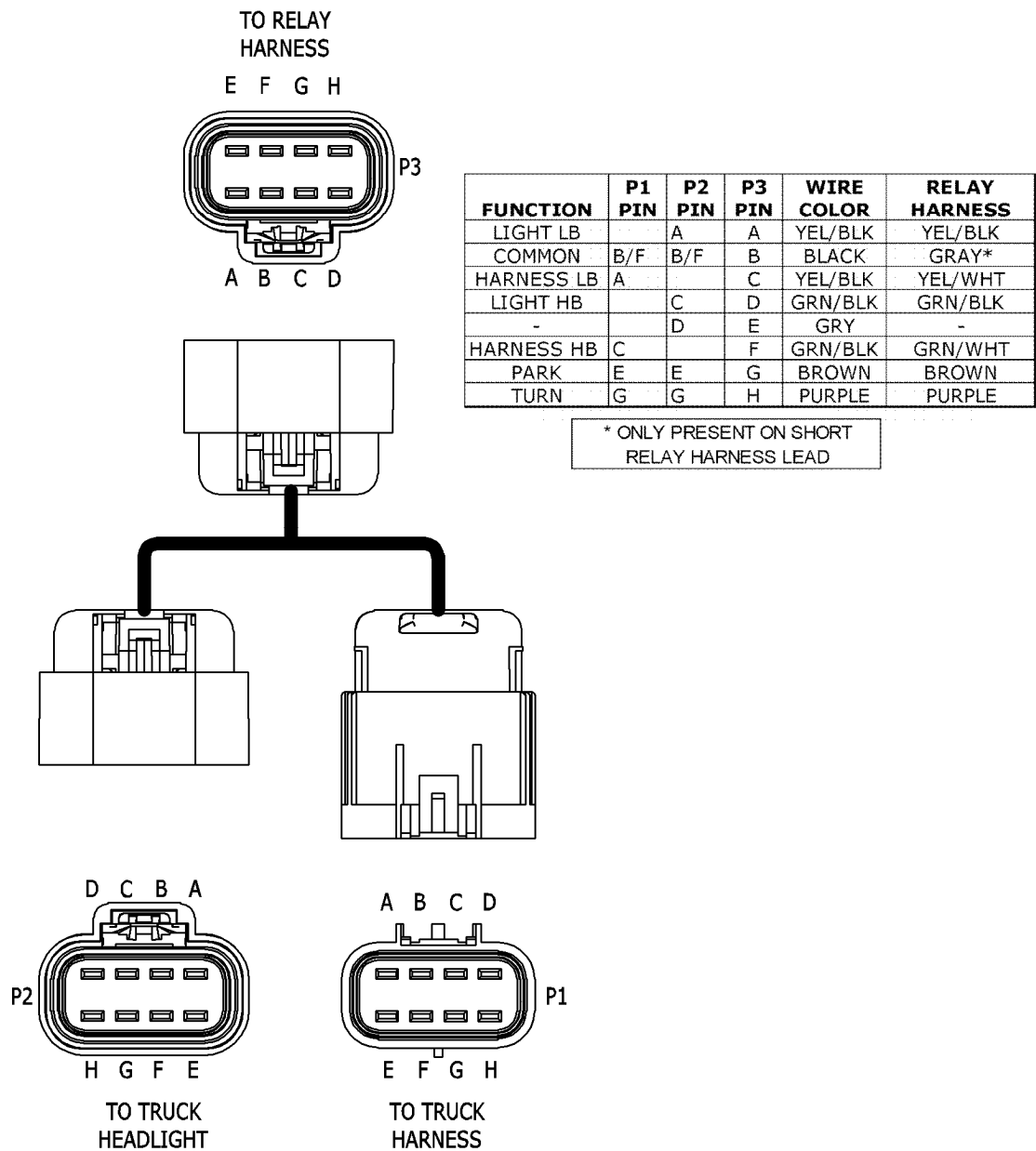

HARNES REFERENCE

16071120
HB5

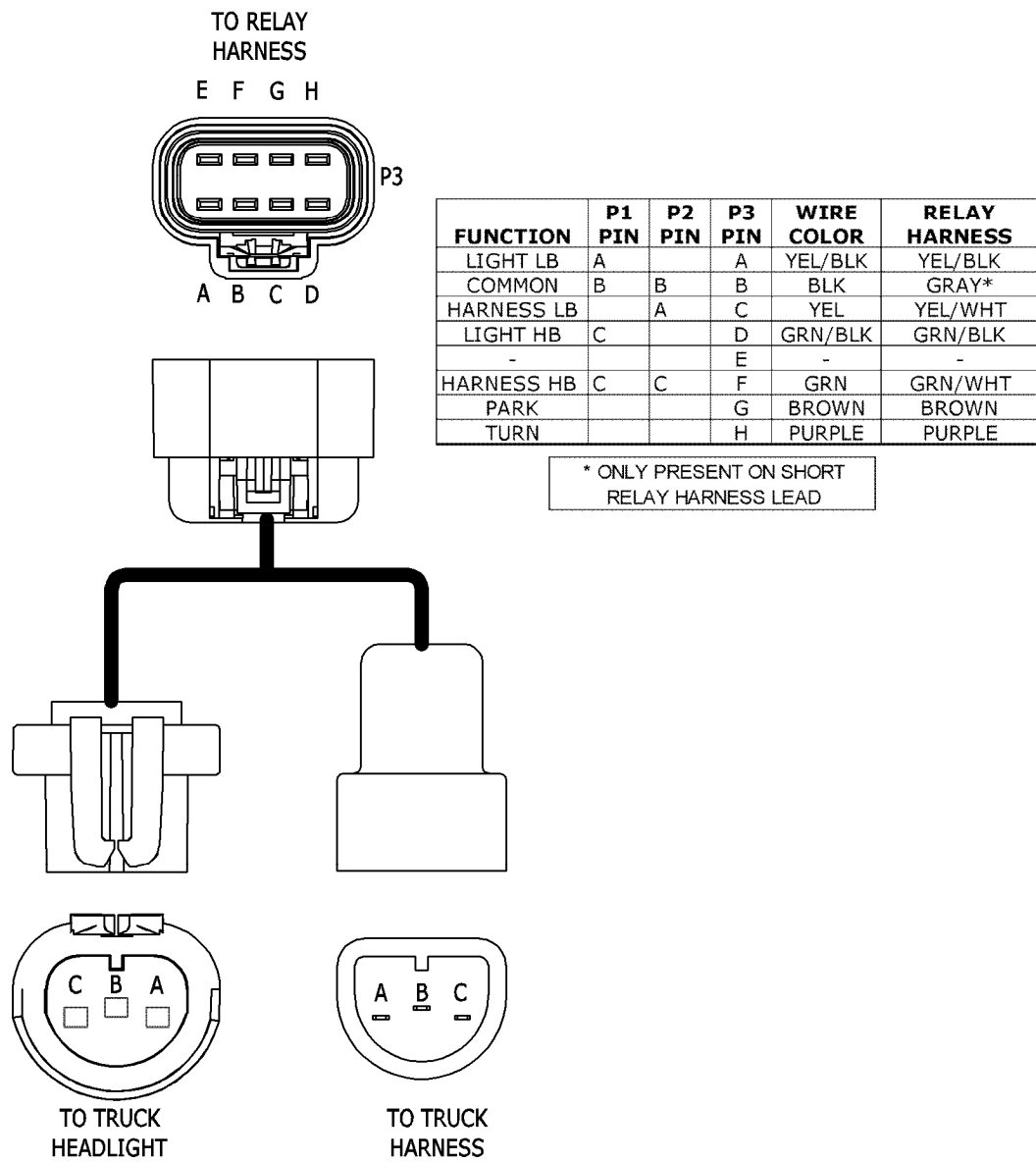

16071130
HB1

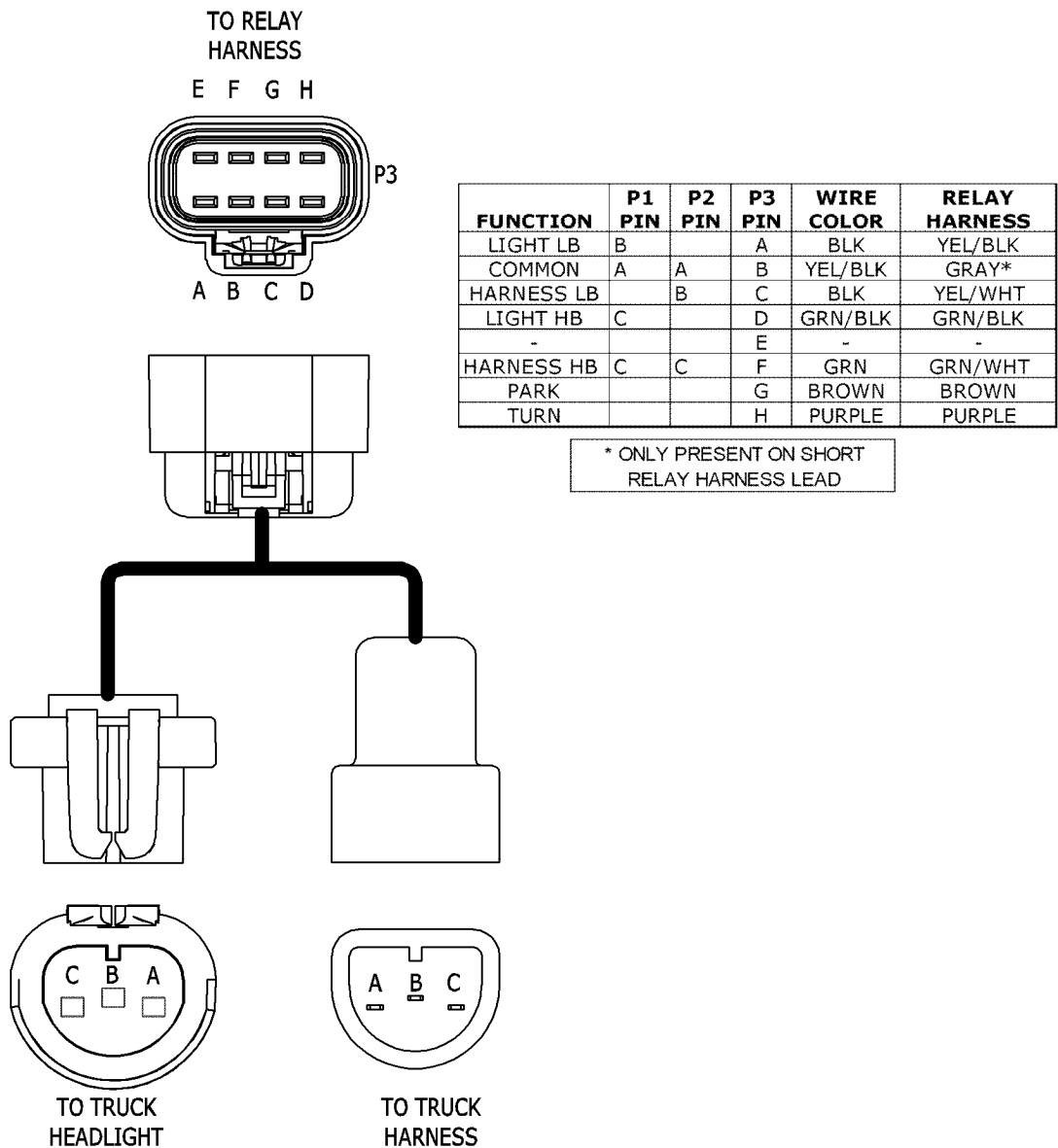

HARNES REFERENCE

16071140
HB2/2B/2D

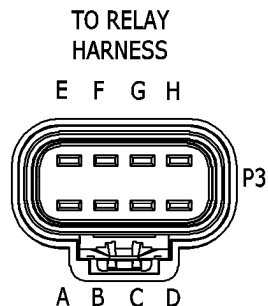

FUNCTION	P1 PIN	P2 PIN	P3 PIN	WIRE COLOR	RELAY HARNESS
LIGHT LB	B		A	BLK	YEL/BLK
COMMON	A	A	B	BLK	GRAY*
HARNESS LB		B	C	YEL	YEL/WHT
LIGHT HB	C	C	D	BLK	GRN/BLK
-			E	-	-
HARNESS HB	C	C	F	GRN	GRN/WHT
PARK			G	BROWN	BROWN
TURN			H	PURPLE	PURPLE

* ONLY PRESENT ON SHORT RELAY HARNESS LEAD

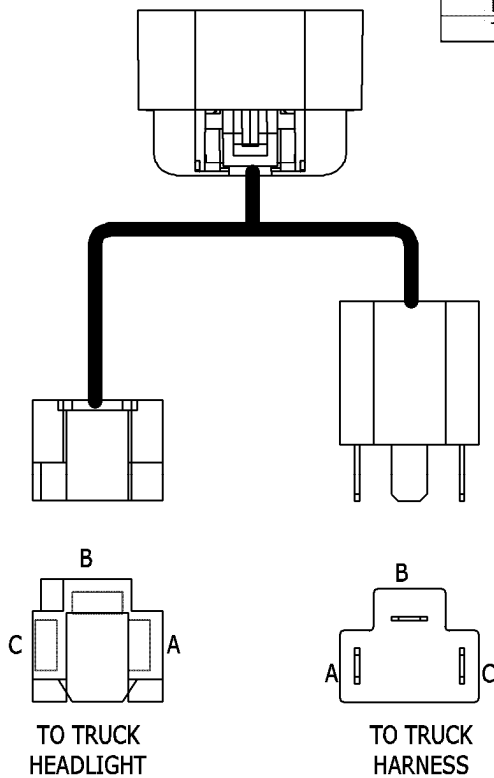

HARNESS REFERENCE

16071150
HB3/HB4

TO RELAY
HARNESS

E F G H

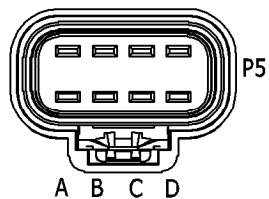

FUNCTION	P1 PIN	P2 PIN	P3 PIN	P4 PIN	P5 PIN	WIRE COLOR	RELAY HARNESS
LIGHT LB	A				A	YEL	YEL/BLK
COMMON	B	B	B	B	B	BLACK	GRAY*
HARNESS LB			A		C	YEL/BLK	YEL/WHT
LIGHT HB		A			D	GRN	GRN/BLK
-					E	-	-
HARNESS HB				A	F	GRN/BLK	GRN/WHT
PARK					G	BROWN	BROWN
TURN					H	PURPLE	PURPLE

* ONLY PRESENT ON SHORT
RELAY HARNESS LEAD

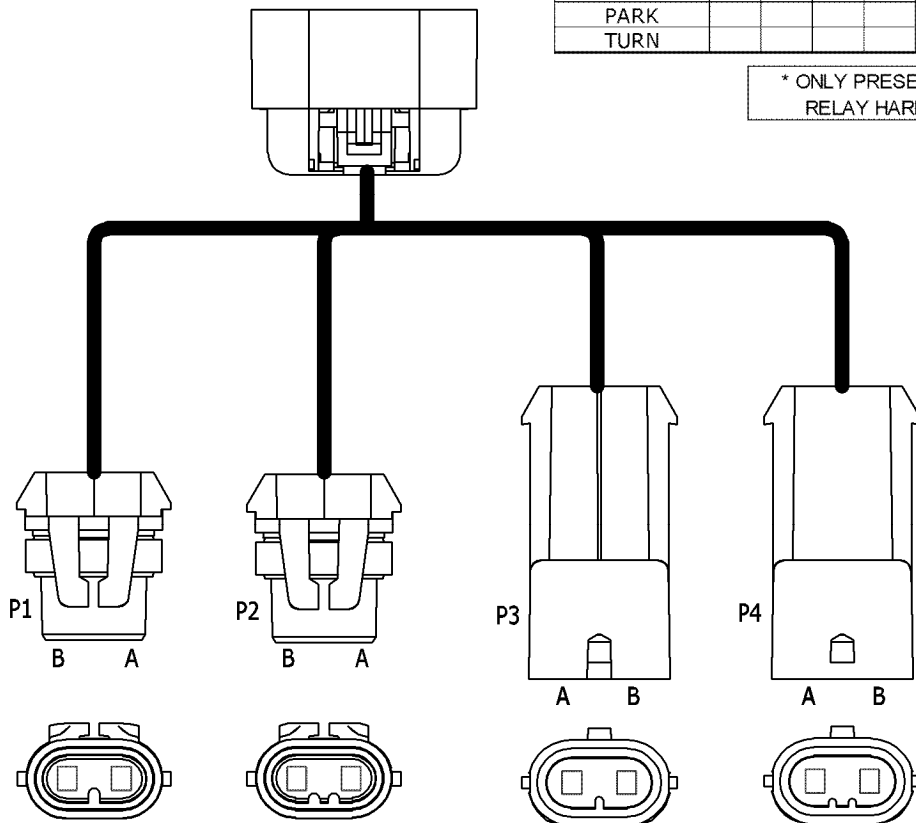

16071150R HB3/HB4 SWITCHED GROUND

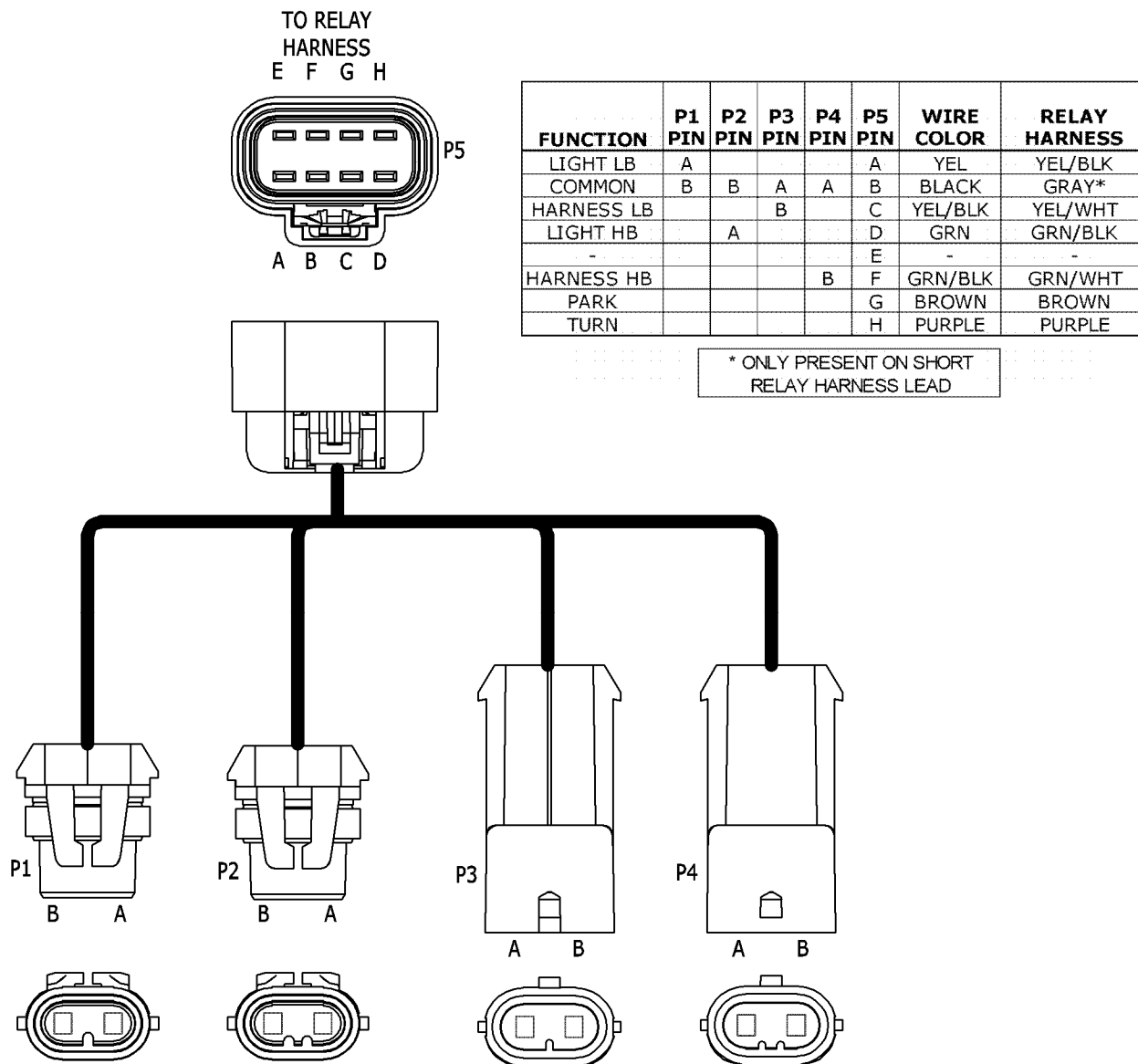

HARNESS REFERENCE

16071160
HB3/H11

TO RELAY
HARNESS

E F G H

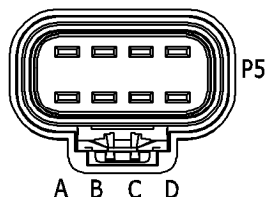

FUNCTION	P1 PIN	P2 PIN	P3 PIN	P4 PIN	P5 PIN	WIRE COLOR	RELAY HARNESS
LIGHT LB	A				A	YEL	YEL/BLK
COMMON	B	B	A	A	B	BLACK	GRAY*
HARNESS LB			B		C	YEL/BLK	YEL/WHT
LIGHT HB		A			D	GRN	GRN/BLK
-					E	-	-
HARNESS HB				B	F	GRN/BLK	GRN/WHT
PARK					G	BROWN	BROWN
TURN					H	PURPLE	PURPLE

* ONLY PRESENT ON SHORT
RELAY HARNESS LEAD

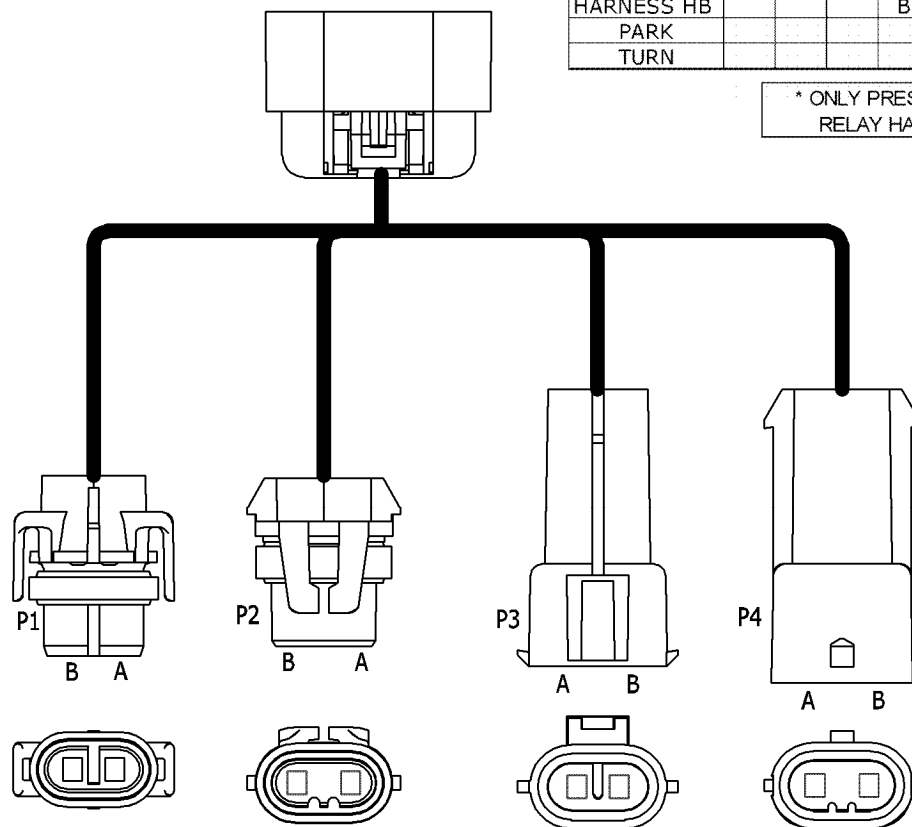

SCHEMATIC REFERENCE

PLOW CONNECTED TRUCK OFF

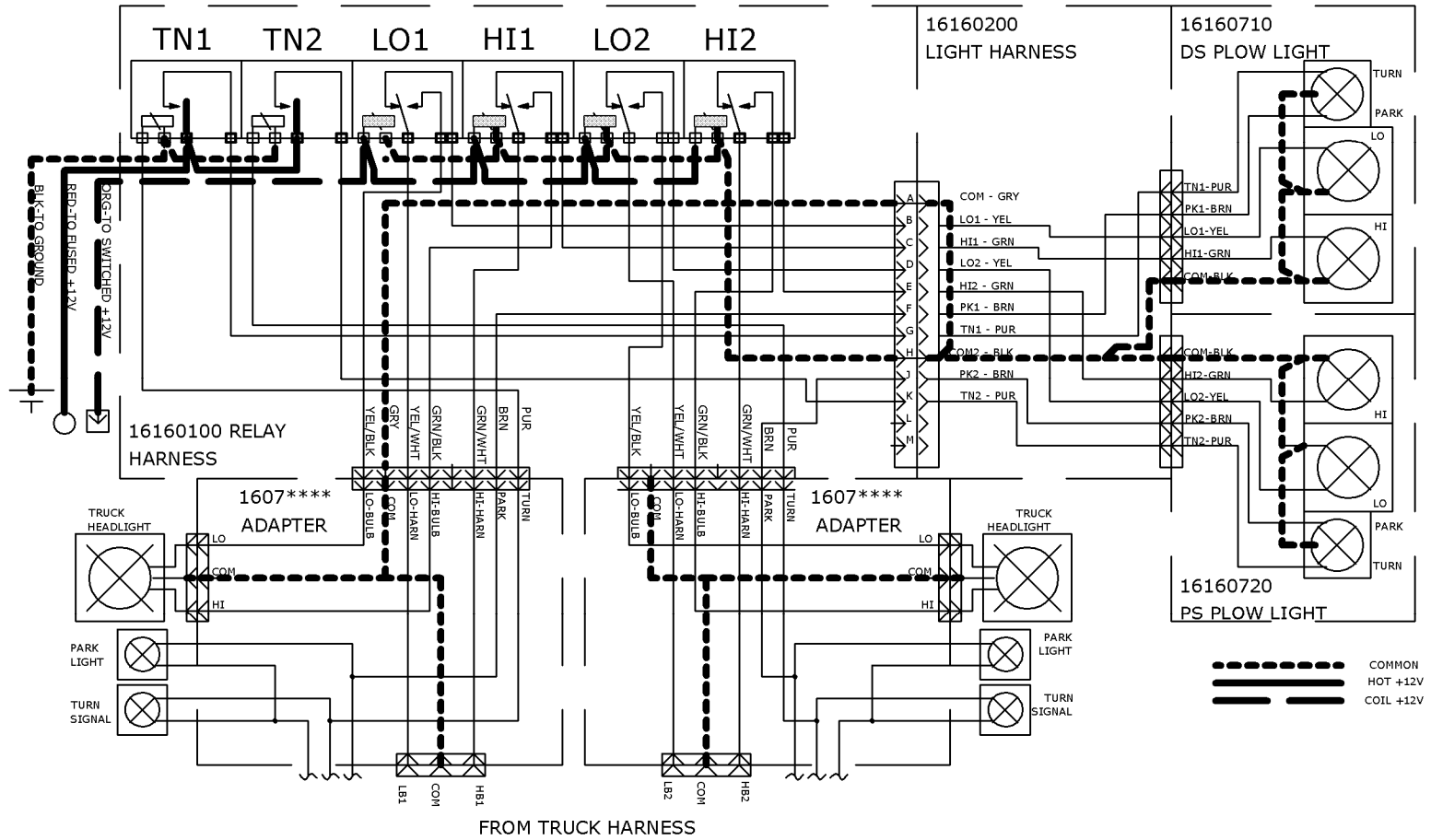

SCHEMATIC REFERENCE

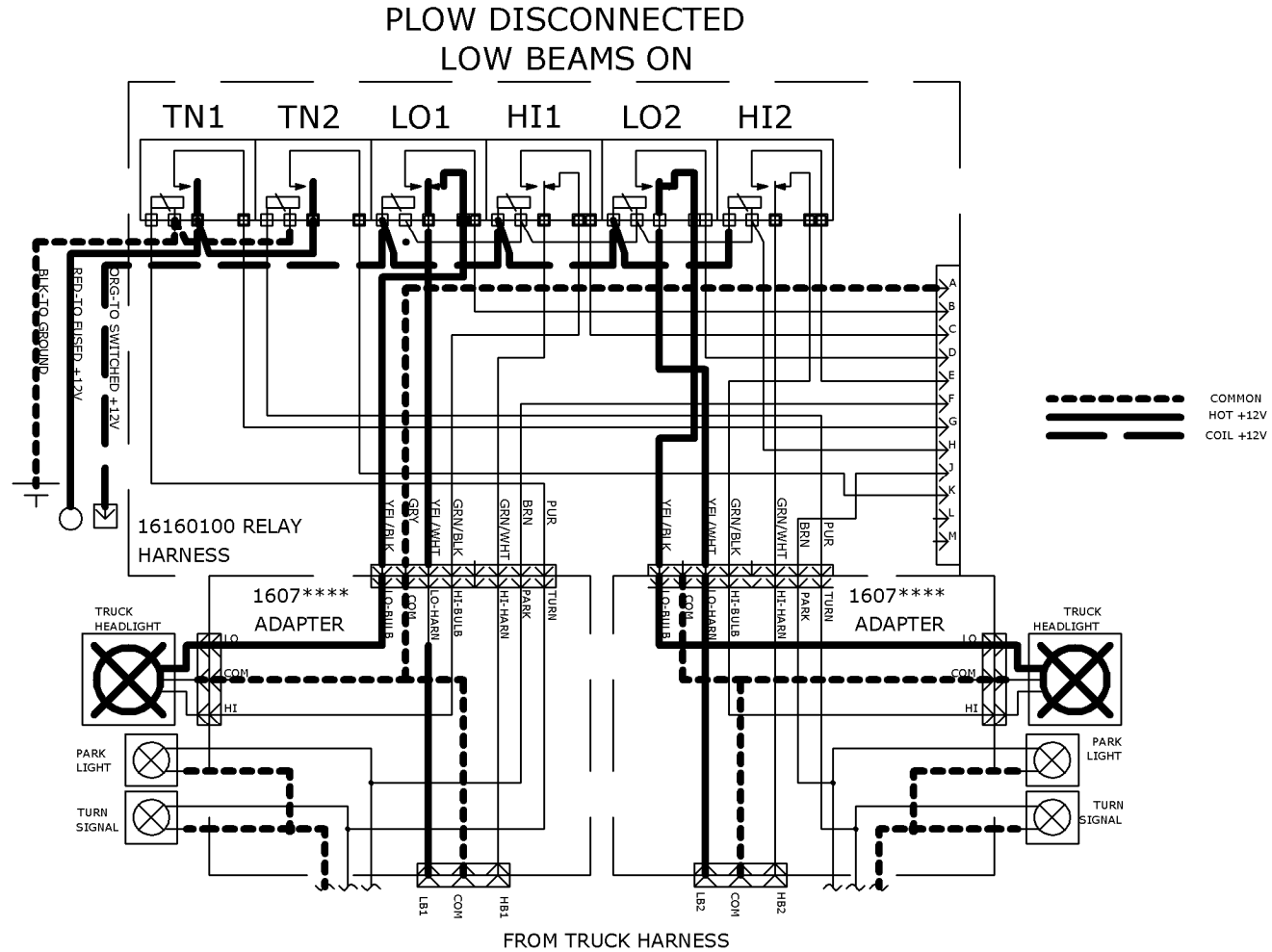

SCHEMATIC REFERENCE

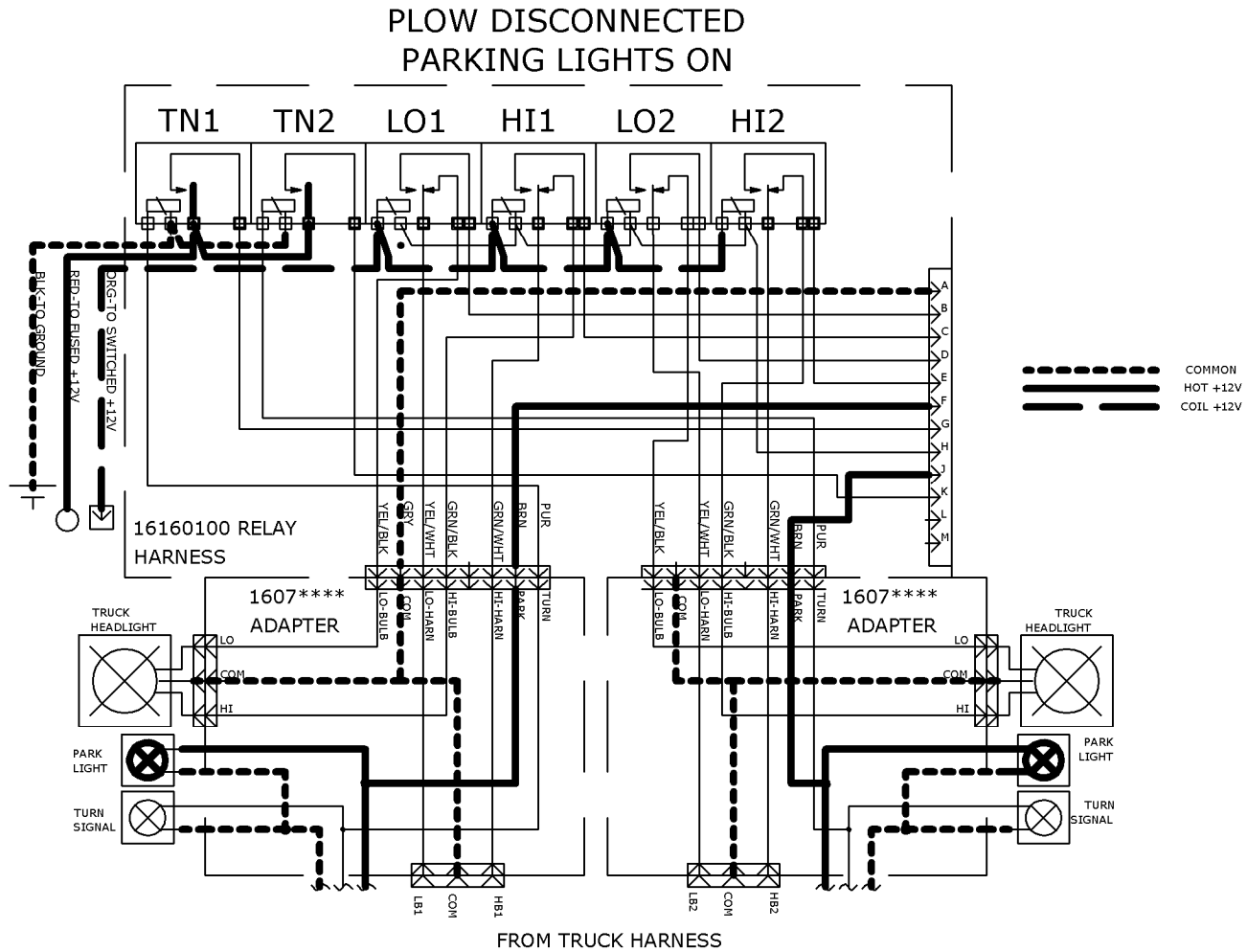

SCHEMATIC REFERENCE

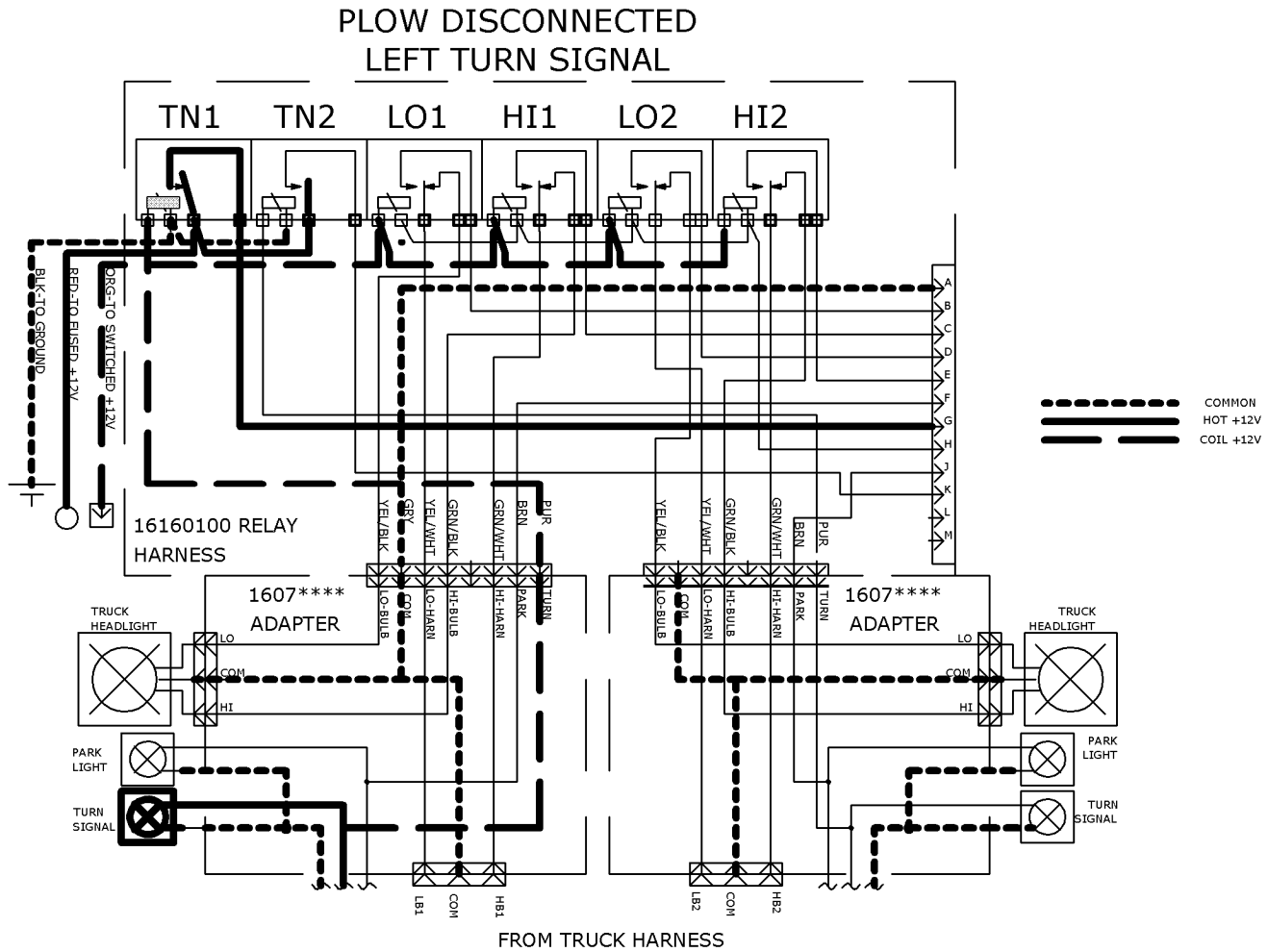

SCHEMATIC REFERENCE

**PLOW CONNECTED
PARKING LIGHTS ON**

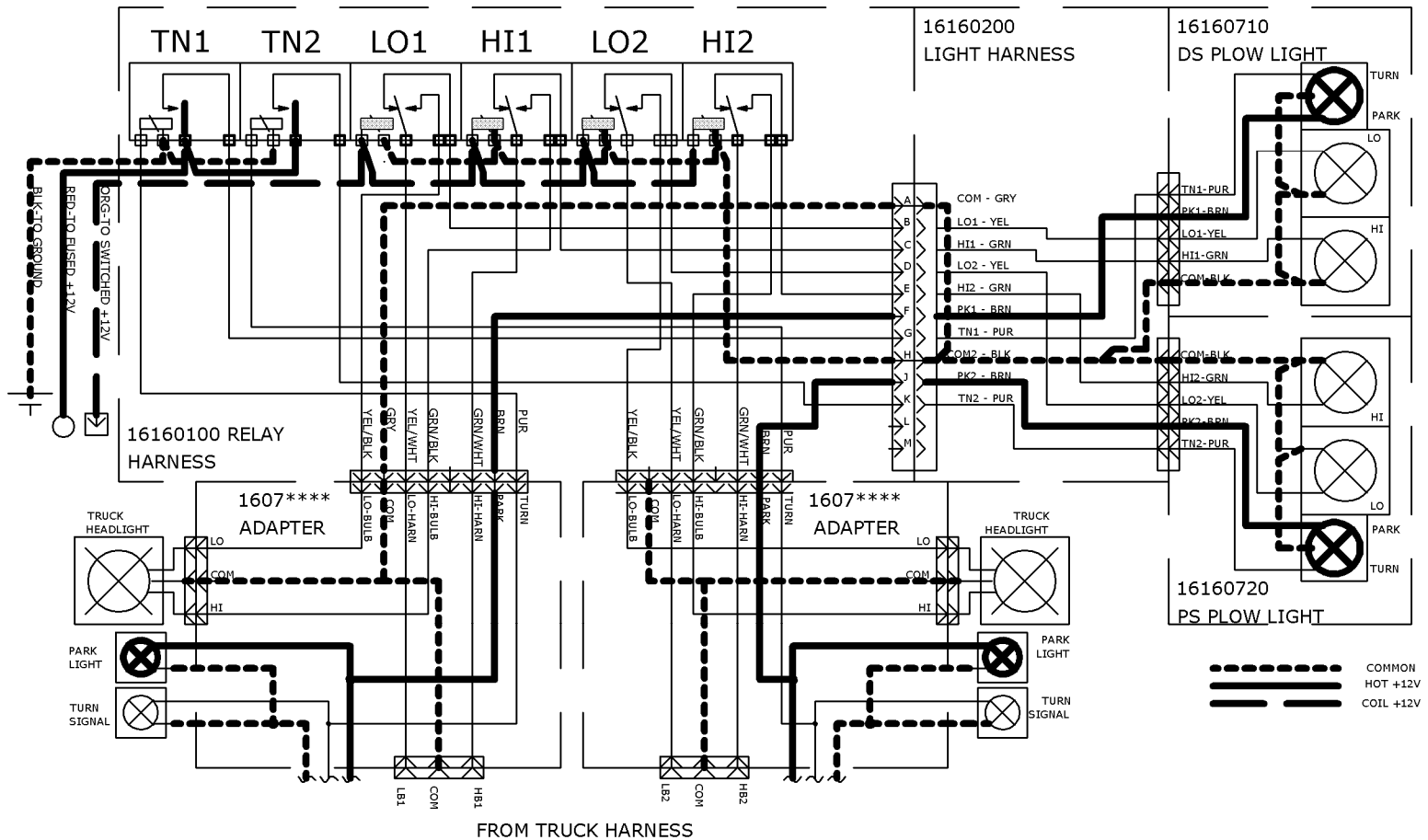

SCHEMATIC REFERENCE

PLOW CONNECTED
LEFT TURN SIGNAL

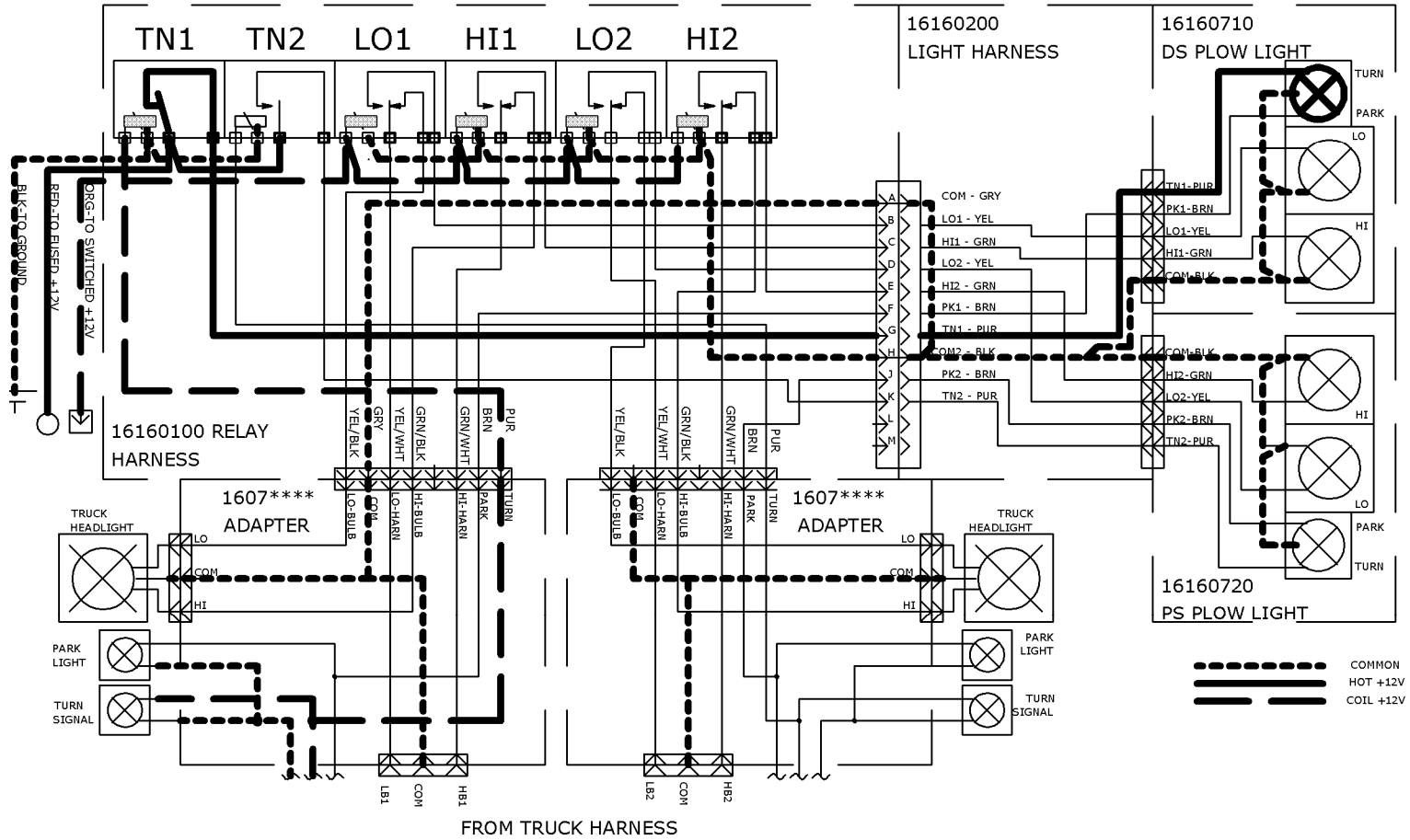

SCHEMATIC REFERENCE

PLOW CONNECTED
LOW BEAMS ON

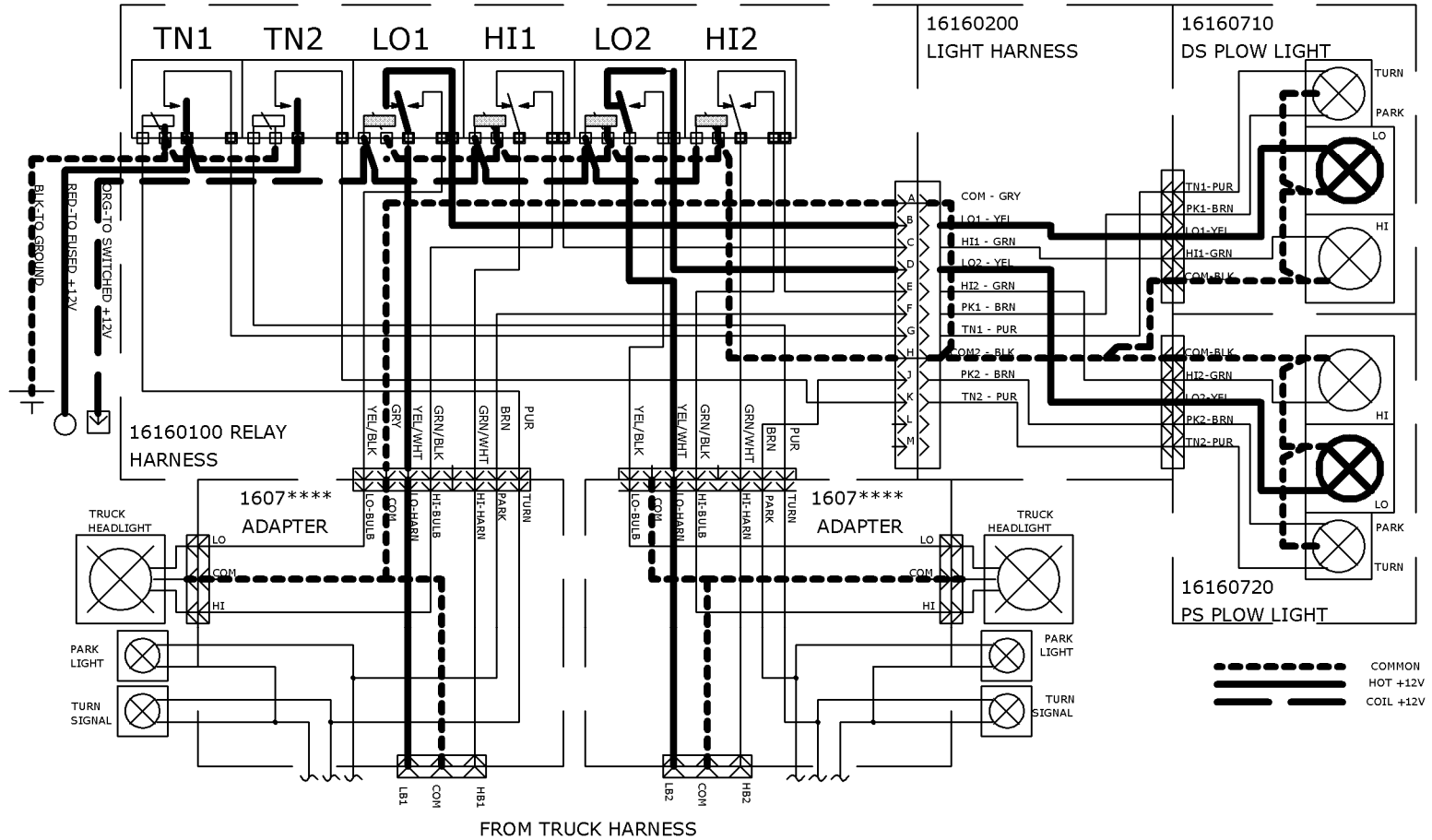

SCHEMATIC REFERENCE

PLOW CONNECTED
HIGH BEAMS ON

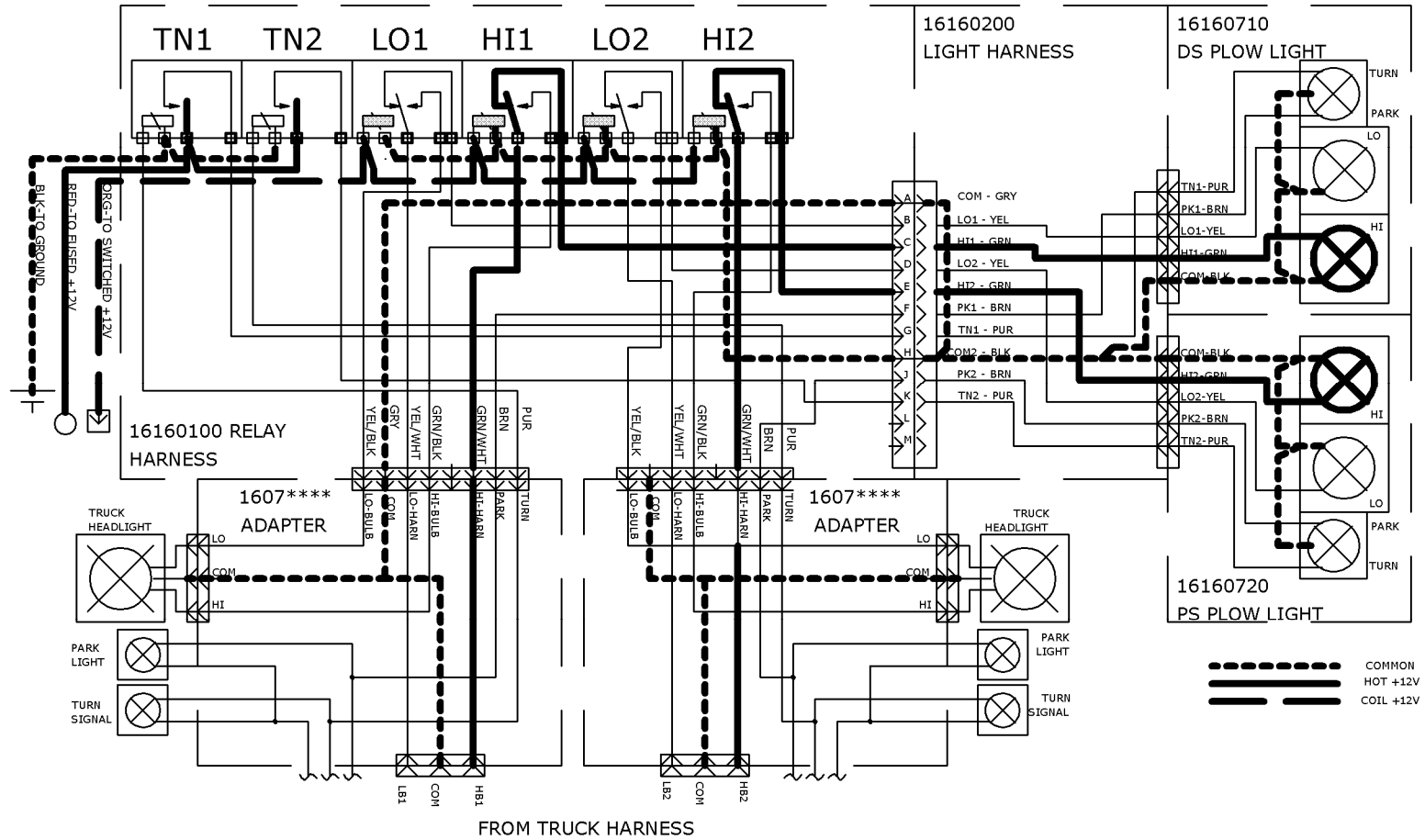

SCHEMATIC REFERENCE
