

SNOWDOGG® HT300 HYDRAULIC REFERENCE

MD/HD/EX/CM PLOWS

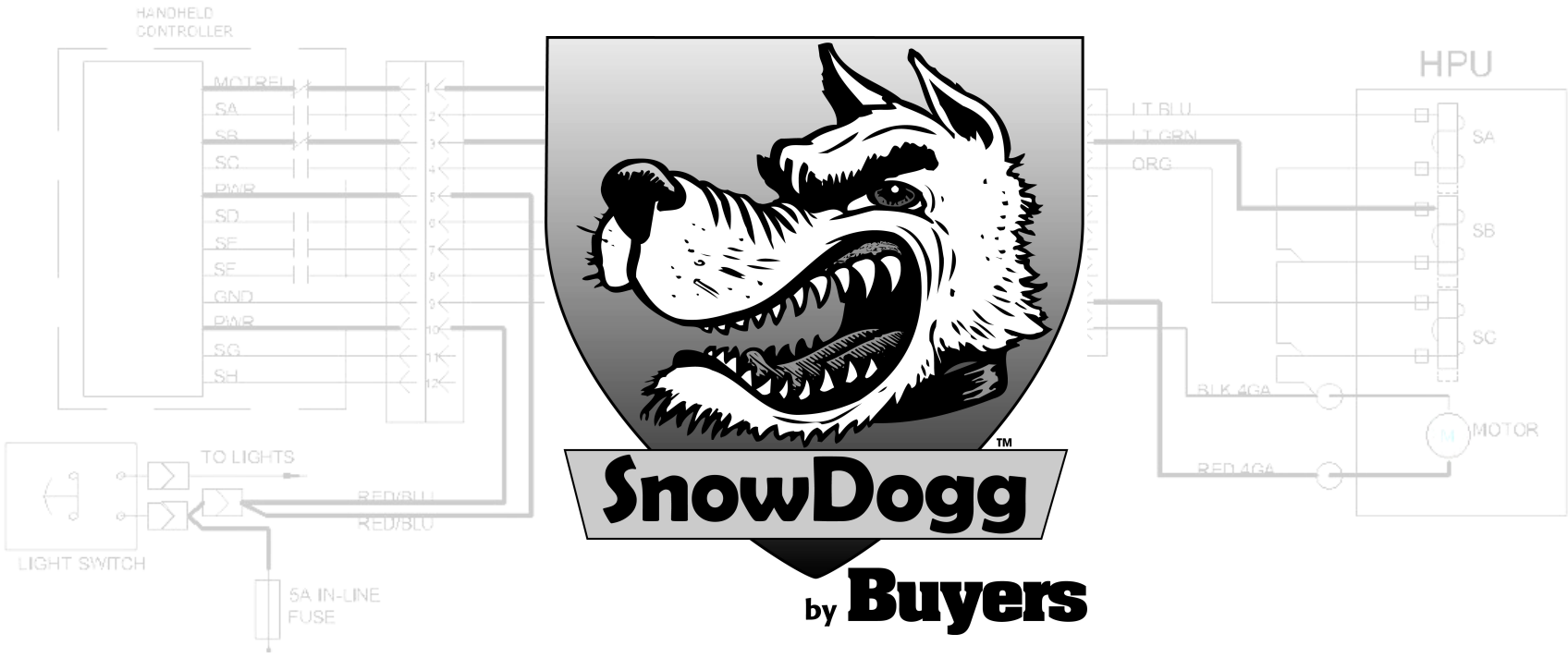

SNOWDOGG HT300 HYDRAULIC REFERENCE

MD/HD/EX/CM PLOWS

GENERAL REFERENCE	3
TROUBLESHOOTING GUIDES/PROCEDURES	5
SCHEMATIC REFERENCE	12
HARNESS REFERENCE	17
CONTROLLER	20

This manual is intended for reference use for troubleshooting. Detailed parts breakdowns may be found in the plow owner's manual.

WARNING

**ANY TROUBLESHOOTING OF THE PLOW ELECTRICAL OR HYDRAULIC SYSTEM MAY RESULT IN UNINTENDED MOTION OF THE PLOW.
ENSURE THAT THE AREA AROUND THE PLOW IS CLEAR TO AVOID SERIOUS INJURY.**

GENERAL REFERENCE

Note

The SnowDogg HT300 hydraulic control circuit is complete separately from the light control circuit.

Any references to wire colors are specific to the control harness.

Method of Operation

Starter Relay

The SnowDogg motor starter relay is the only component of the hydraulic system mounted under the hood and is always connected. Even with the plow disconnected, the starter relay will click if the controller is powered and LIFT, LEFT or RIGHT are pressed.

Hydraulic Solenoids

Three hydraulic solenoid valves are used in the HT300 power unit. They all use the same coil – so coils can be swapped to aid in troubleshooting. The solenoid coils act as electromagnets, and pull on an armature and spool or poppet inside the valve. A valve may malfunction due to faulty wiring, a bad coil, or contamination preventing the armature/spool from freely moving inside the valve. If the problem is contamination, it can often be corrected by removing and cleaning the valve. If the issue is electrical, the valve will not energize or shift. If the problem is mechanical, the valve may not shift or may be stuck in the shifted position.

Controller

The hand held digital controller controls both the starter relay coil and the hydraulic solenoids. It can withstand a continuous short circuit without damage. It has integral diagnostics to aid in troubleshooting and to notify the user of an electrical fault.

Proper Operation of HT300 Power Unit

Controller

After hitting POWER, the SnowDogg logo should be lit and the controller status light (upper right corner) should be solid GREEN. If the status light is blinking, see troubleshooting.

Lift Button

Plow lifts until lift cylinder is at end of stroke and fluid is diverted over the main relief valve at 1900PSI.

Right Button

Plow right side moves towards the truck. At the end of stroke, fluid is diverted over the main relief valve at 1900 PSI.

GENERAL REFERENCE

Left Button

Plow left side moves towards the truck. At end of stroke, fluid is diverted over the main relief valve at 1900 PSI.

Lower Button

Plow drops until the blade hits the ground or until the cylinder is fully retracted.

Float (hold Lower Button for >.5 seconds)

Float light is lit and plow drops until the blade hits the ground or until the cylinder is fully retracted – and the drop valve remains energized allowing the blade to follow the ground (depending on how the chain is set).

TROUBLESHOOTING

Troubleshooting Tips

- The wires to the coils are in alphabetical order from front to back. **BLUE-SA, GREEN-SB, ORANGE-SC.**
- Check for magnetism at the coils with a screwdriver or metal tool. With the coil energized, you should feel a magnetic pull at the top of the coil.
- If the controller is blinking, the problem is electrical – not hydraulic. Do not spend time troubleshooting and cleaning valves if the controller is blinking.
- Use a test light to measure for +12V at coils and connectors.
- Use a multimeter/ohmmeter to measure for continuity.
- Always start troubleshooting with the moldboard straight and on the ground.

Tools Recommended

- Multimeter (Voltmeter/Ohmmeter)
- Wrenches
- 7/8" deep socket (for solenoid valves)
- Picks (for removing/replacing o-rings)
- Buyers High Performance Hydraulic Fluid (P/N 1307010/1307015)

TROUBLESHOOTING

Symptom	Cause	Resolution	Tests
The plow does not move at all, pump is not running	Motor or Motor Relay is not activating	Check Motor/Motor Relay	TS1
The plow will not lift, but will angle left and right	SB valve is either contaminated or not being energized	Clean/Replace SB valve	See page 21
The plow will not drop, but lifts and angles	SA valve is either contaminated or not being energized	Clean/Replace SA valve	See page 21
The plow will not angle right, but drops, lifts, and angles left	SC valve is either contaminated or not being energized	Clean/Replace SC valve	See page 21
Plow will not lift, and angles slowly, if at all	Main Relief valve is contaminated	Clean/replace Main Relief valve	TS3
	Pump is damaged	Check Pump	
	Motor is not functioning properly	Check Motor	
Plow does not lock in position when angling	Angle lock valve is contaminated or faulty	Clean/replace Angle Lock Valve	See page 21
	Crossover relief valve is contaminated or faulty	Clean/replace Crossover Relief valve	See page 21
Status light is blinking once	Starter Relay has electrical fault	Troubleshoot wiring	TS1

TROUBLESHOOTING

Status light is blinking 2 time	Plow was connected after controller was turned on	Turn controller off and back on	
	SA valve (blue wire) has electrical fault	Troubleshoot wiring	TS2
Status light is blinking 3 times	SB valve (Green wire) has electrical fault	Troubleshoot wiring	TS2
Status light is blinking 4 times	SC valve (Orange wire) has electrical fault	Troubleshoot wiring	TS2

HPU SERVICING

Fill Procedure

1. Remove the fill plug from the reservoir.
2. The reservoir should be $\frac{1}{2}$ – $\frac{2}{3}$ full.

SA/SB/SC valve service/replacement

1. Remove the coil from the solenoid valve.
2. Using a $\frac{7}{8}$ " socket, remove the solenoid valve from the manifold.
3. Inspect the valve for contamination or damage.
4. Ensure that the poppet or spool travels freely.
5. Flush the valve if necessary to remove contamination.
6. Reinstall valve and tighten to 20 ft-lbs.

Lift Check Valve service/replacement

1. Remove the Lift Port Fitting
2. Remove the SA solenoid valve
3. Use tool 16900010 to remove the Lift Check Valve
4. There is a Teflon and rubber seat underneath the check valve that can be removed with a pick.
5. Ensure that the poppet travels freely.
6. Flush the valve if necessary to remove contamination.
7. Reinstall valve and tighten to 10 ft-lbs.

General valve service/replacement

1. Using a socket, remove the valve from the manifold.
2. Inspect the valve for contamination or damage.
3. Ensure that the poppet or spool travels freely.
4. Flush the valve if necessary to remove contamination.
5. Reinstall valve and tighten to 20 ft-lbs.

NOTE: Always lubricate components with oil prior to reassembly to prevent damage to the o-rings.

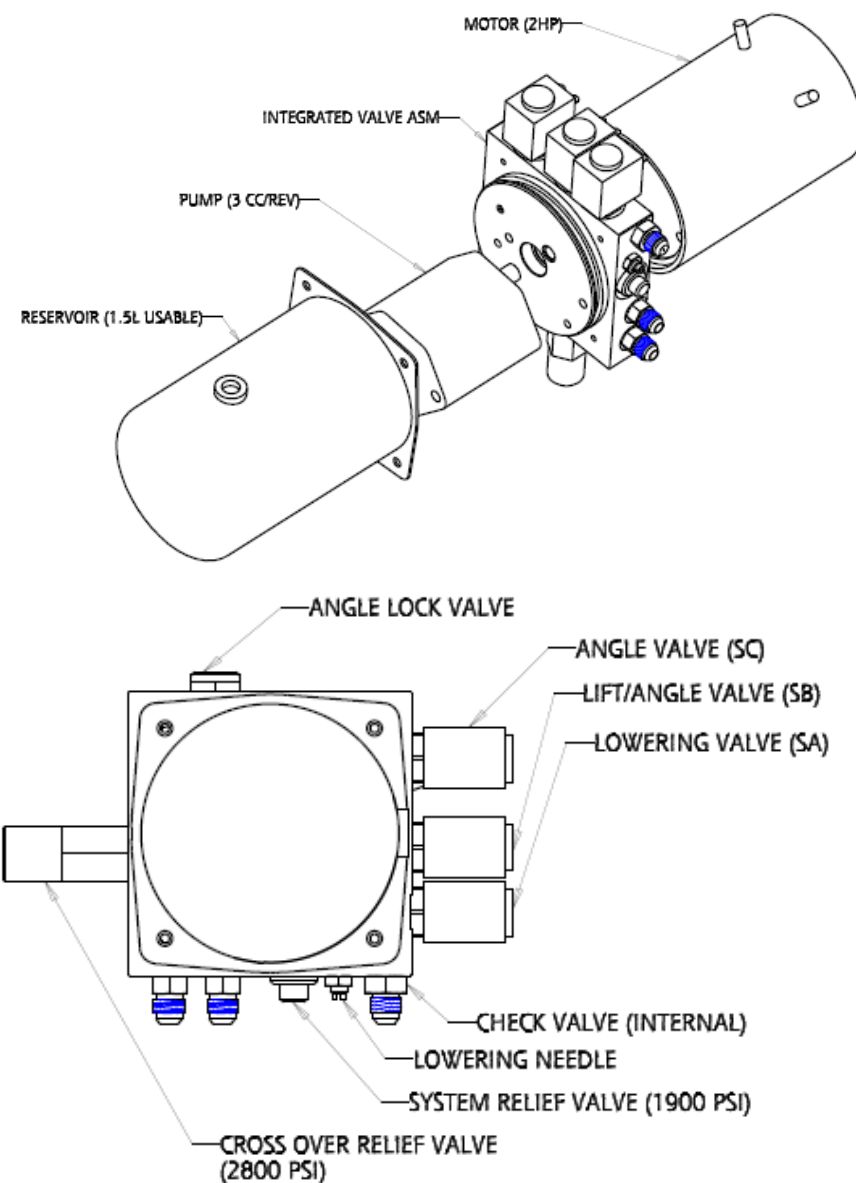

WARNING

ANY TROUBLESHOOTING OF THE PLOW ELECTRICAL OR HYDRAULIC SYSTEM MAY RESULT IN UNINTENDED MOTION OF THE PLOW.
ENSURE THAT THE AREA AROUND THE PLOW IS CLEAR TO AVOID PROPERTY DAMAGE OR SERIOUS INJURY
ALL MAINTENANCE MUST BE PERFORMED WITH MOLDBOARD ON THE GROUND

TS1 HPU Motor not running

1. With controller on, press LIFT, LEFT or RIGHT. Listen for starter relay “CLICK”
 - Click not heard
 - Check for +12V at relay control terminals (small terminals)
 - Ground for relay should be to battery
 - Click heard
 - Continue
2. Jump the large terminals of the starter relay with a large wire or screwdriver.
 - If HPU motor runs
 - Replace starter relay
 - If HPU motor does not run
 - Continue
3. Disconnect plow – check for +12V at large sockets of grill connector (truck side controller harness)
 - If +12V is not present
 - Check wiring continuity between starter relay and grill connector and battery ground and grill connector
 - If +12V is present
 - Continue
4. Check continuity between plow side connector and studs on HPU motor
 - If continuity is NOT found
 - Check wires
 - If continuity is found
 - Continue
5. Disconnect Red wire from HPU motor, directly apply +12V to HPU motor (from extra battery or using jumper cables)
 - If motor runs
 - Motor is not defective, check wiring

TROUBLESHOOTING

If motor does not run

Motor is defective, replace

TS2 General Coil Troubleshooting – Blinking Status Light

1. Turn Controller OFF, waiting five seconds, turn Controller ON
2. Hit UP/LEFT/RIGHT/DOWN in sequence and watch the plow.
 - Plow is operating correctly / status light is not blinking
Complete
 - Plow is operating correctly / status light IS blinking
There is an intermittent short/open circuit.
Clean and check all connection points
Look for frayed/pinched/damaged wires
Continue
 - Plow is NOT operating correctly / status light IS blinking
Continue
3. Check for +12V at coil terminals (2 blinks – BLUE, 3 blinks – GREEN, 4 blinks – ORANGE)
 - If +12V is present
Coil is defective, replace
 - If +12V is not present
Check ground side wire continuity
Continue
4. Check for continuity on +12V wire between coil and grill connector (see pinout)
 - If continuity is NOT found
Repair/replace plow side harness
 - If continuity is found
Continue
5. Check for continuity between grill connector and controller connector (in cab)
 - If continuity is NOT found
Repair/replace truck side control harness
 - If continuity is found
Check controller connector pins and verify everything is seated properly.
Try a known good controller
6. Contact SnowDogg Tech Support

TROUBLESHOOTING

TS3 System Pressure Check

1. Disconnect the lift cylinder hose from the manifold
2. Install a pressure gage on the lift port
3. Energize the LIFT circuit and read the gage pressure
 - Pressure is over 1800 PSI
 - Pressure is correct
 - Pressure is under 1800 PSI
 - Replace/clean the Main Relief Valve
4. Repeat pressure gage test with new Main Relief
 - Pressure is over 1800 PSI
 - Problem resolved
 - Pressure is under 1800 PSI
 - Replace/clean the SA valve (Blue Wire)
5. Repeat pressure gage test with new SA valve
 - Pressure is over 1800 PSI
 - Problem resolved
 - Pressure is under 1800 PSI
 - Call SnowDogg Tech Support

LIFT

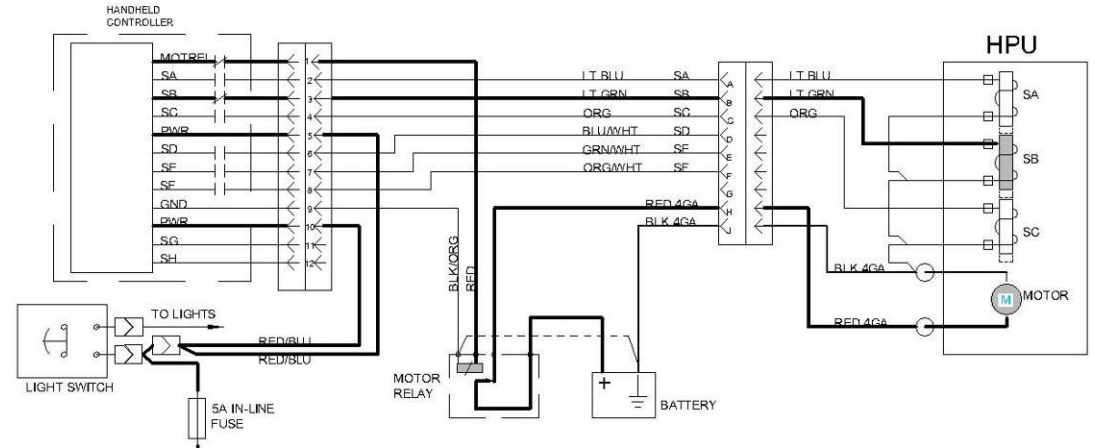
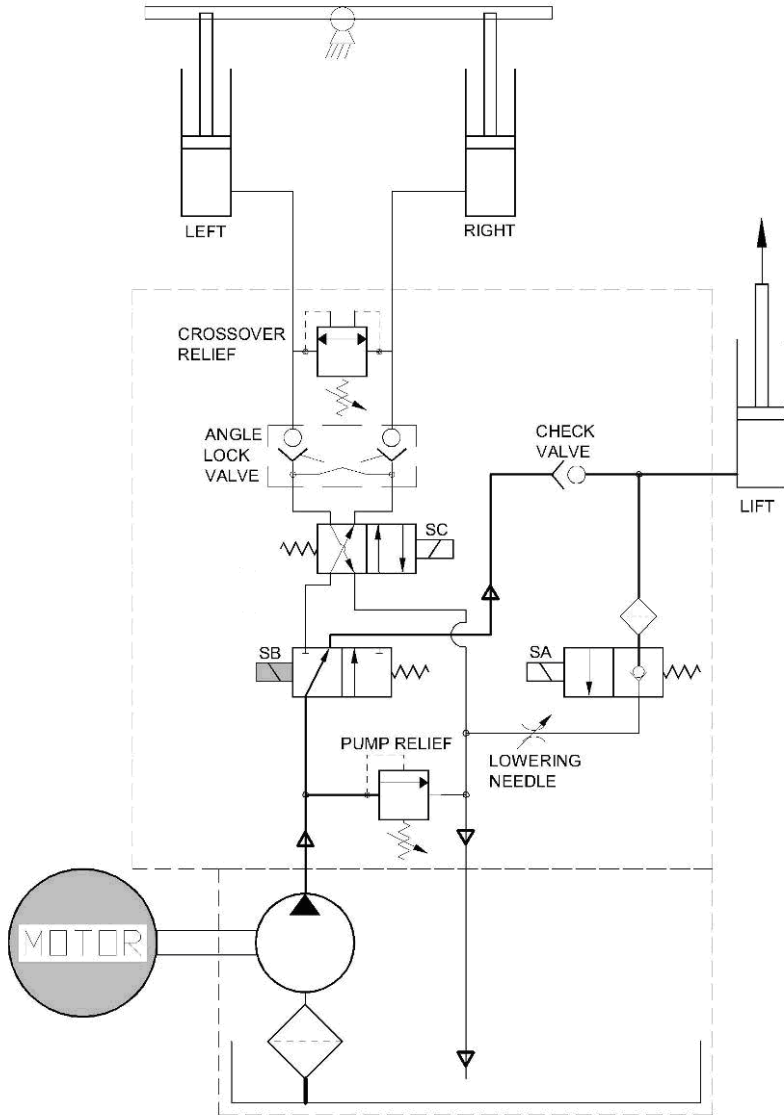

When the LIFT button is pressed, the MOTOR and VALVE SB are energized and fluid from the pump is diverted by VALVE SB through the CHECK VALVE and into the lift cylinder. VALVE SA remains closed, preventing the lift cylinder from retracting.

If the cylinder reaches end of stroke or the lift cylinder is blocked while the LIFT button is pressed, oil goes through the PUMP RELIEF to the reservoir. The controller will shut off after 10 seconds to protect the motor.

When the LIFT button is released, the MOTOR and VALVE SB de-energize. The CHECK VALVE and VALVE SA block return flow, keeping the lift cylinder locked in position.

LOGIC TABLE				
	MOTOR	SA	SB	SC
LIFT	1	-	1	-
LOWER	-	1	-	-
LEFT	1	-	-	-
RIGHT	1	-	-	1

LOWER/FLOAT

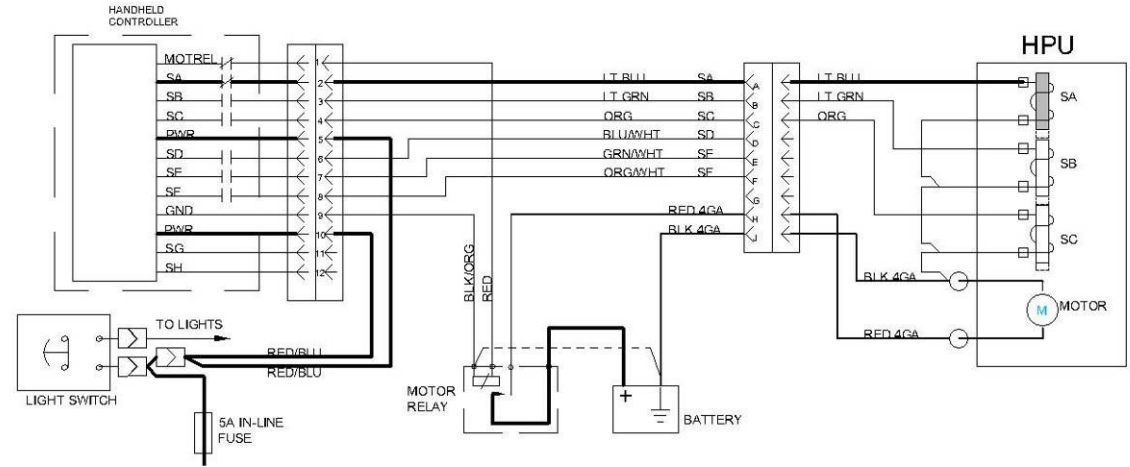
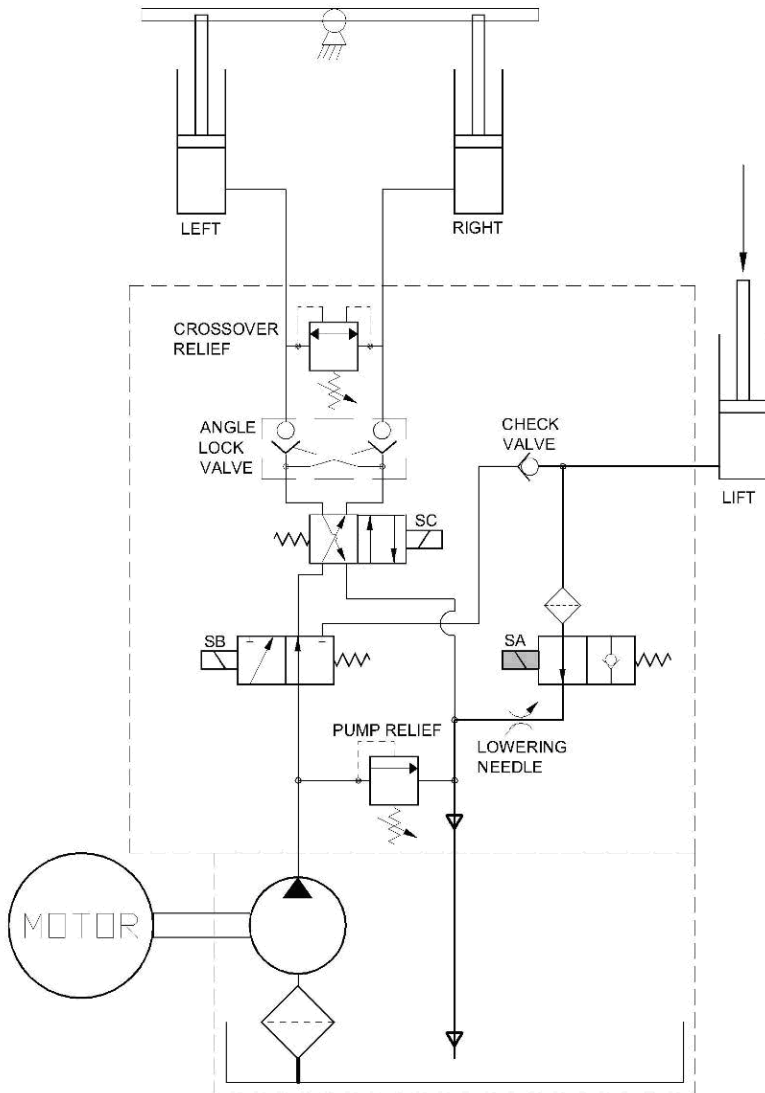

When the LOWER button is pressed, valve SA is energized and fluid from the lift cylinder is drained to tank through valve SA and the LOWERING NEEDLE to the reservoir.

If the LOWER button is held for more than one second, the controller goes into FLOAT mode and lights the FLT indicator. In this mode, valve SA remains energized allowing the chain to go slack and for the moldboard to follow the ground.

If the LOWER button is released prior to FLOAT mode being activated, valve SA de-energizes. The check valve and valve SA block return flow from the cylinder, keeping the lift cylinder locked in position.

FLOAT mode is deactivated immediately by pressing the LIFT button. The plow may be angled while in FLOAT mode.

LOGIC TABLE				
	MOTOR	SA	SB	SC
LIFT	1	-	1	-
LOWER	-	1	-	-
FLOAT	-	1	-	-
LEFT	1	-	-	-
RIGHT	1	-	-	1

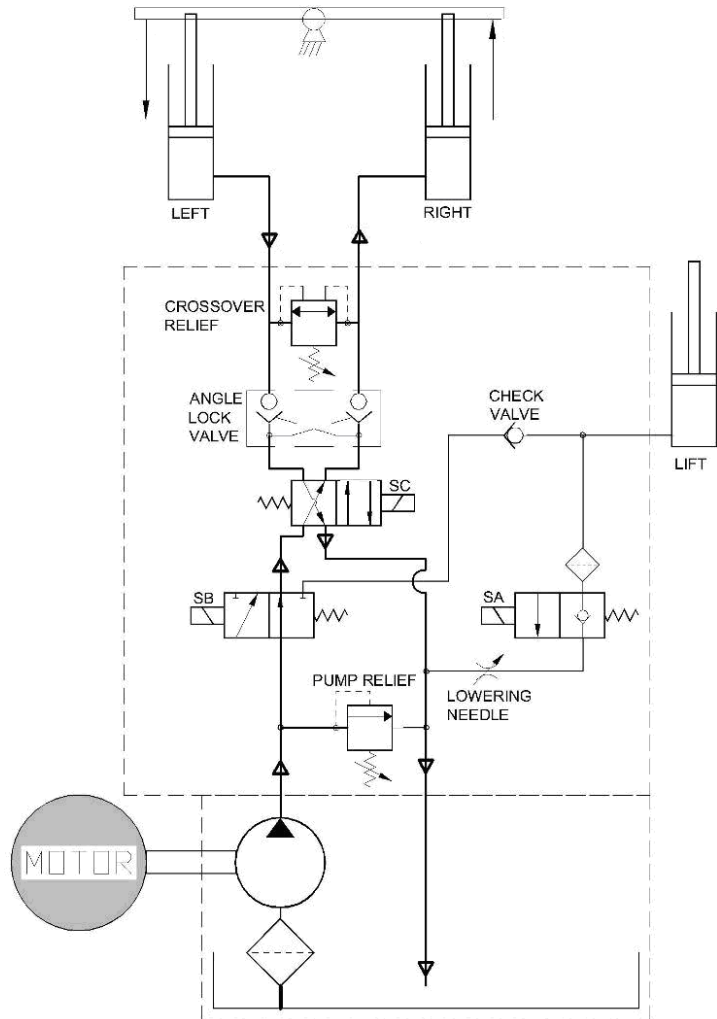

LEFT

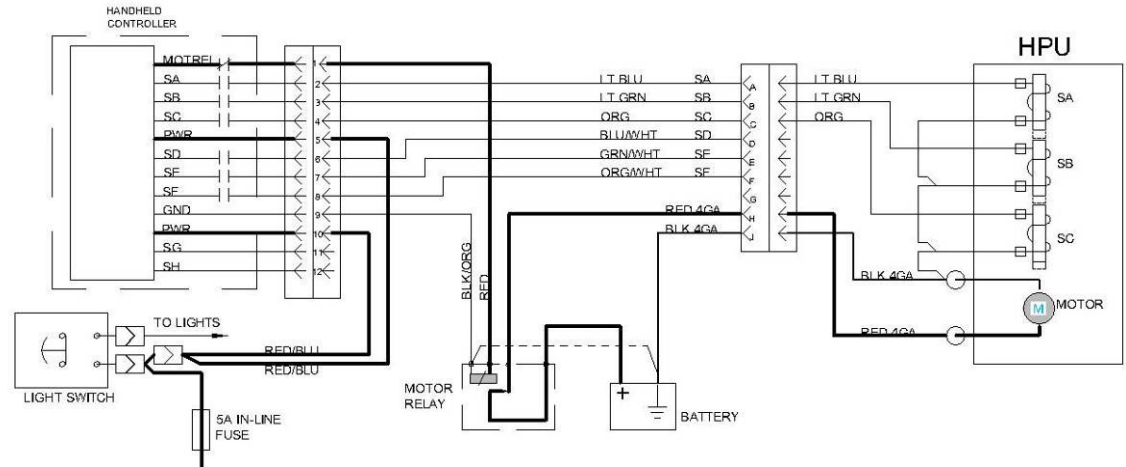

When the LEFT button is pressed, the MOTOR is energized and fluid goes through valves SB, SC and ANGLE LOCK valve to the LEFT cylinder. As the LEFT cylinder extends, the RIGHT cylinder retracts, sending fluid back through the ANGLE LOCK valve (held open by pressure from the pump) and valve SC to tank.

If the cylinder reaches end of stroke or the LEFT or RIGHT cylinder are blocked while the LEFT button is pressed, oil goes through the PUMP RELIEF to the reservoir. The controller will shut off after 10 seconds to protect the motor.

When the LEFT button is released, the motor de-energizes and the LEFT and RIGHT cylinders are locked in position by the ANGLE LOCK valve.

LOGIC TABLE				
	MOTOR	SA	SB	SC
LIFT	1	-	1	-
LOWER	-	1	-	-
FLOAT	-	1	-	-
LEFT	1	-	-	-
RIGHT	1	-	-	1

SCHEMATIC REFERENCE

RIGHT

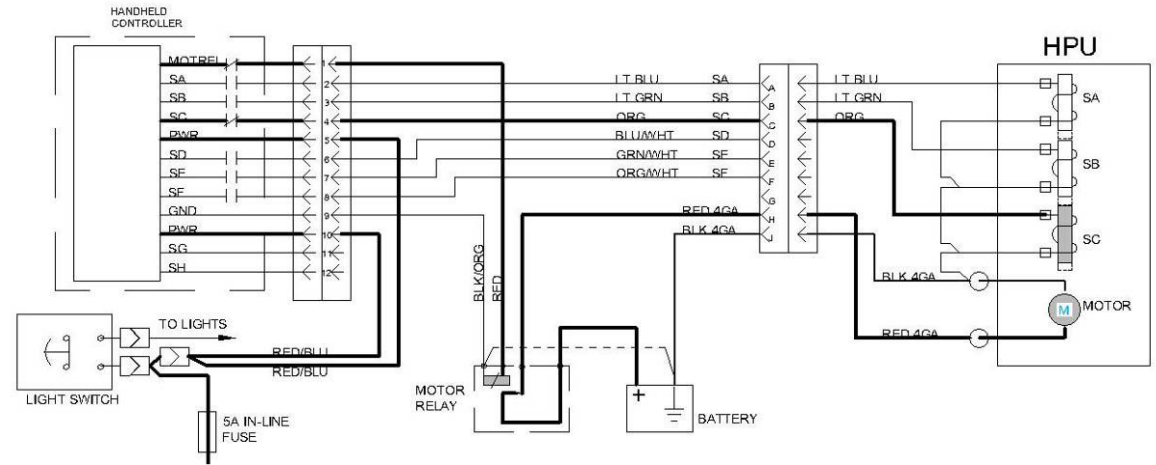
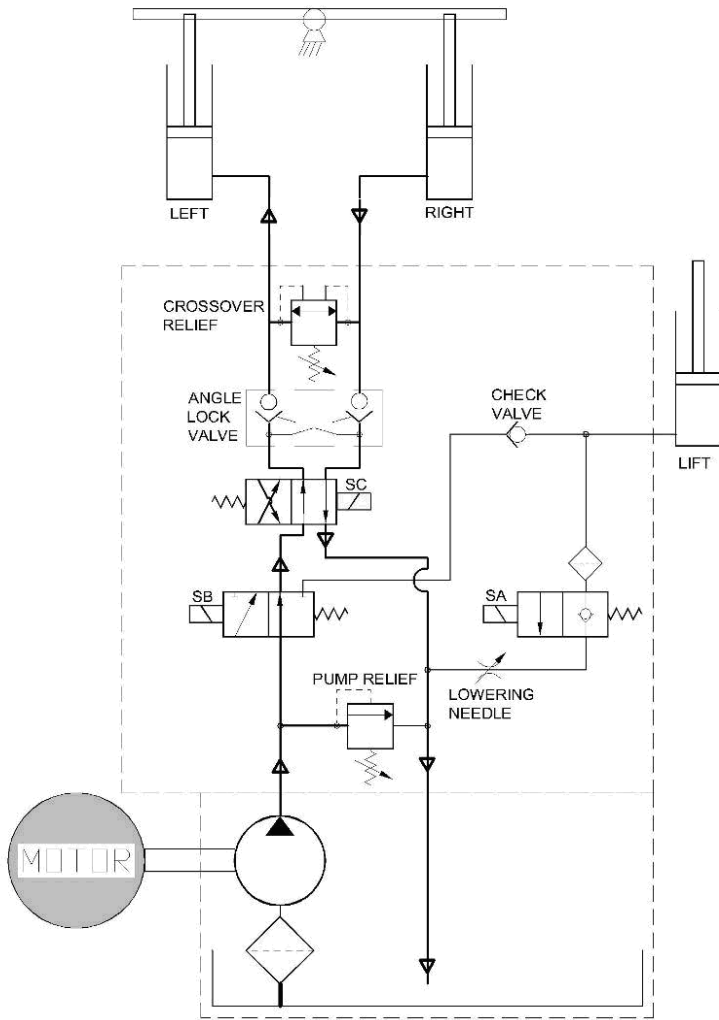

When the RIGHT button is pressed, the MOTOR and valve SC are energized and fluid goes through valves SB, SC and the ANGLE LOCK valve to the RIGHT cylinder. As the RIGHT cylinder extends, the LEFT cylinder retracts, sending fluid back through the ANGLE LOCK valve (held open by pressure from the pump) and valve SC to tank.

If the cylinder reaches end of stroke or the LEFT or RIGHT cylinder are blocked while the RIGHT button is pressed, oil goes through the PUMP RELIEF to the reservoir. The controller will shut off after 10 seconds to protect the motor.

When the RIGHT button is released, the motor and valve SC de-energize and the LEFT and RIGHT cylinders are locked in position by the ANGLE LOCK valve.

LOGIC TABLE				
	MOTOR	SA	SB	SC
LIFT	1	-	1	-
LOWER	-	1	-	-
FLOAT	-	1	-	-
LEFT	1	-	-	-
RIGHT	1	-	-	1

CROSS RELIEF

When sufficient external force (driving into an obstacle) is applied to one end of the moldboard, the cylinder being loaded will retract and fluid will travel to the other cylinder through the CROSSOVER RELIEF. This protects the moldboard and plow from mechanical damage. The plow will most likely trip as well, providing further protection.

When the external loading is removed, the CROSSOVER RELIEF will close and allow normal plow operation.

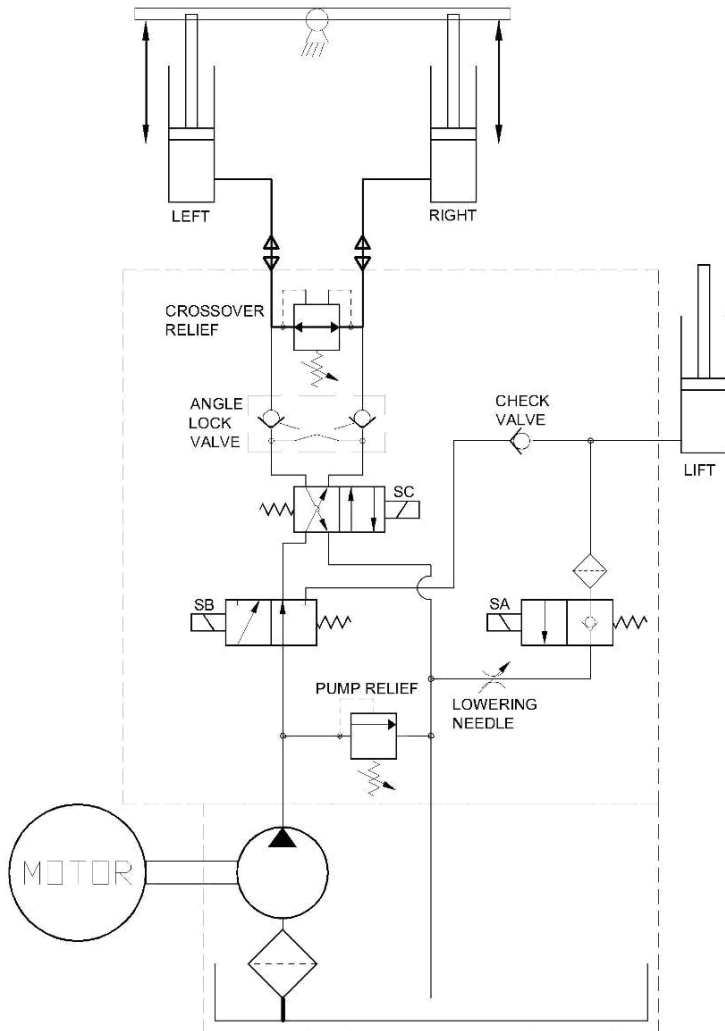

LOGIC TABLE				
	MOTOR	SA	SB	SC
LIFT	1	-	1	-
LOWER	-	1	-	-
FLOAT	-	1	-	-
LEFT	1	-	-	-
RIGHT	1	-	-	1

TRUCK/PLOW HARNESS

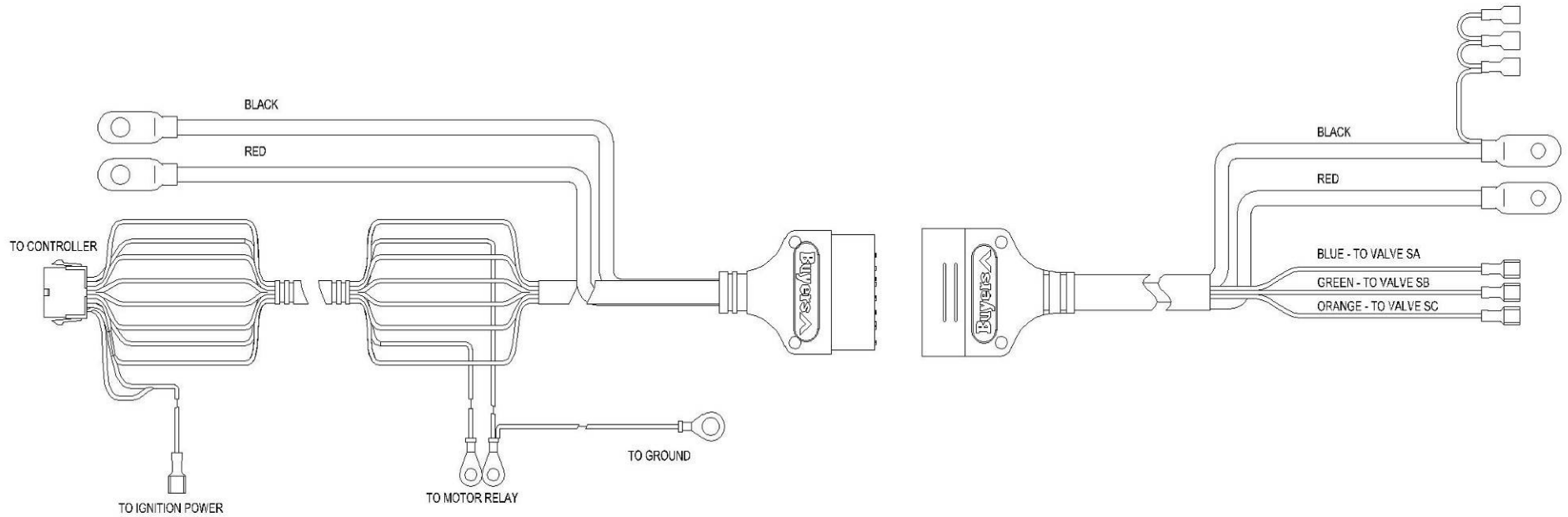

The portion on the left is the TRUCK HARNESS, and is routed between the bumper (plow interface) and under the dashboard (for the controller and ignition power connections). The portion on the right is the PLOW HARNESS and comes pre-assembled to the plow. It is used during assembly for the initial plow setup and testing.

The plow harness is separate from the light harness for ease of installation and service. All under hood wiring uses SAE standard GXL and TXL insulation (per OEM specs). The power wires to the motor are 4ga. This reduces voltage drop (power loss) at high current loads. The harness has designed with extra length to accommodate the variety of truck battery and firewall bulkhead locations.

The TRUCK HARNESS is V-Plow ready, so in the future no re-installation will be required for a plow upgrade.

TRUCK SIDE HARNESS PINOUT

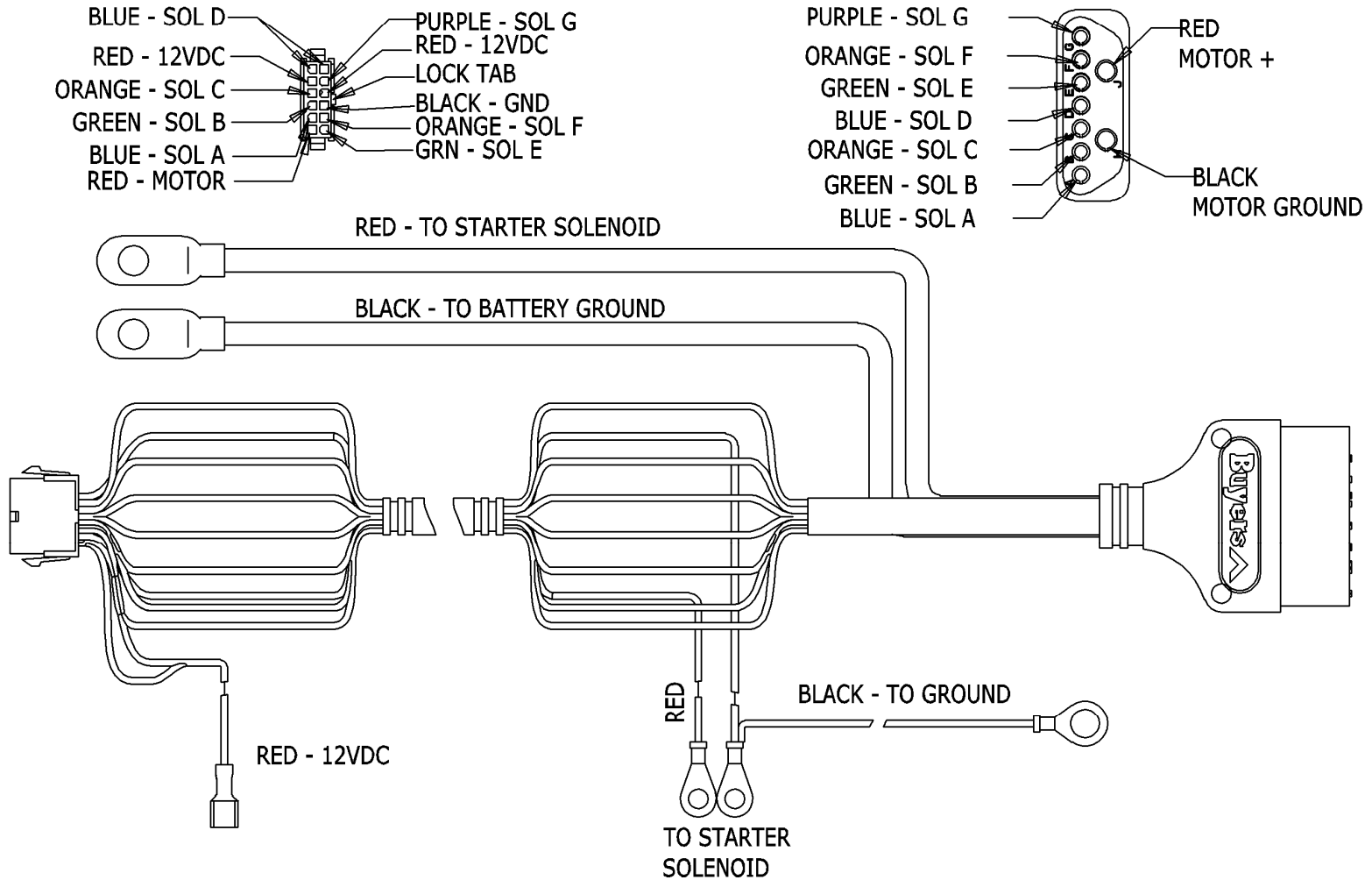

PLOW HARNESS PINOUT

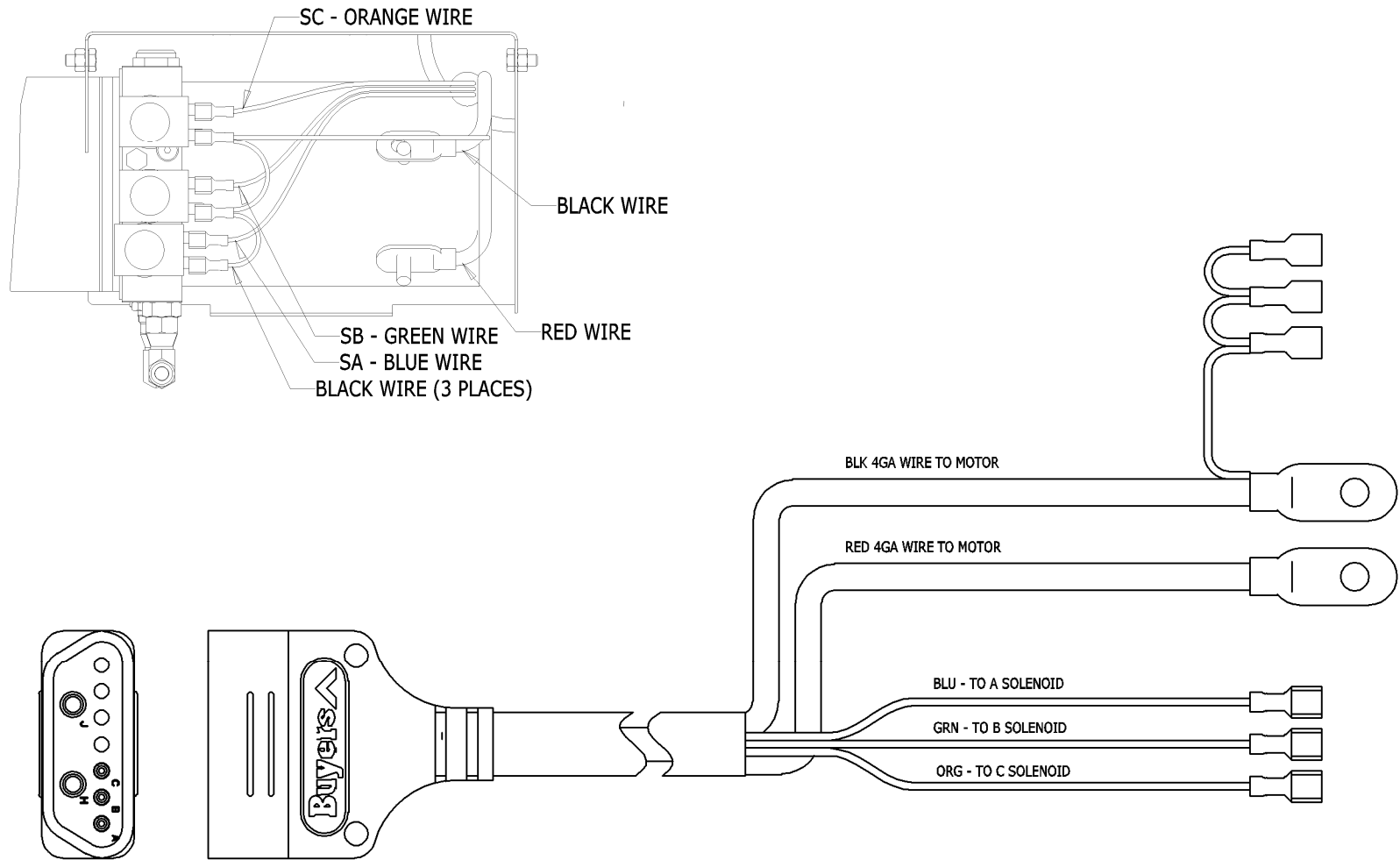

SNOWDOGG CONTROLLER

The SnowDogg controller uses fault tolerant drivers that can withstand shorts to ground without failure. The failure of a single channel will not affect the performance of the remaining channels.

If the fault is intermittent it will be registered, but will not cause the controller to stop functioning.

Function specific timings have been incorporated into the controller to ensure that no unintended movement takes place.

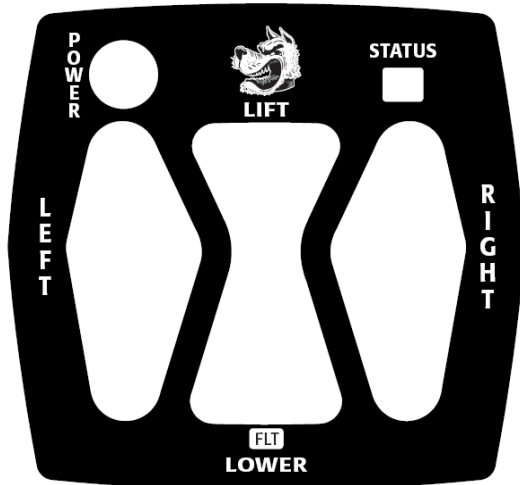

CONTROLLER SPECIFICATIONS

- **Electrical**
 - 8 independent channels
 - 5A per channel
 - Digital “Smart Drivers”
 - Reprogrammable
- **Functional**
 - Integral diagnostics
 - “Diagnostic” mode

CONTROLLER STATES

Normal Operation – No Errors

- See the HPU specifications and schematics for a description of the effect of individual buttons
- Controller will time out in 10 seconds if button is not released

Normal Operation – With Errors

- Controller continues to operate – “error” channels are shutdown only if in short condition.
- Yellow (Float) light will go solid
- Red (Status) light will blink the channel # in error
- If the fault is momentary the controller will continue to display the fault – the fault can be reset by turning the controller off and back on. This allows intermittent faults (broken wires, worn insulation) to be detected.

CONTROLLER DIAGNOSTIC MODE

Enter diagnostic mode with the following sequence.

1. Disconnect the controller from power (turn truck off)
2. Hold down the POWER button and turn truck on
3. Continue holding down POWER button until GREEN status LED begins to blink (10 seconds)
4. You are now in "Diagnostic" mode. All outputs are off.
5. Use the buttons/leds as shown to test each channel

- **GREEN STATUS LED**
 - Blinks the # of the channel currently selected
- **RED STATUS LED**
 - SOLID when selected channel is shorted
 - BLINKS when selected channel is open (broken)
- **YELLOW STATUS LED**
 - SOLID in any error condition in selected channel
- **RIGHT**
 - Increase the channel number being tested
 - This will turn off ALL channels
- **LEFT**
 - Decrease the channel number being tested
 - This will turn off ALL channels
- **UP**
 - Turns ON selected channel
- **DOWN**
 - Turns OFF selected channel

Exit diagnostic mode by turning the controller off and back on.

CONTROLLER OUTPUT TABLE

LOGIC TABLE				
CHANNEL	1	2	3	4
	MOTOR	SA	SB	SC
		DROP	LIFT/ANGLE	ANGLE
	RED	BLUE	GREEN	ORANGE
LIFT	1	-	1	-
LOWER	-	1	-	-
FLOAT	-	1	-	-
LEFT	1	-	-	-
RIGHT	1	-	-	1

