

SNOWDOGG® 16151000 (HT300) SCHEMATIC REFERENCE

MD/HD/EX/TE/CM PLOWS

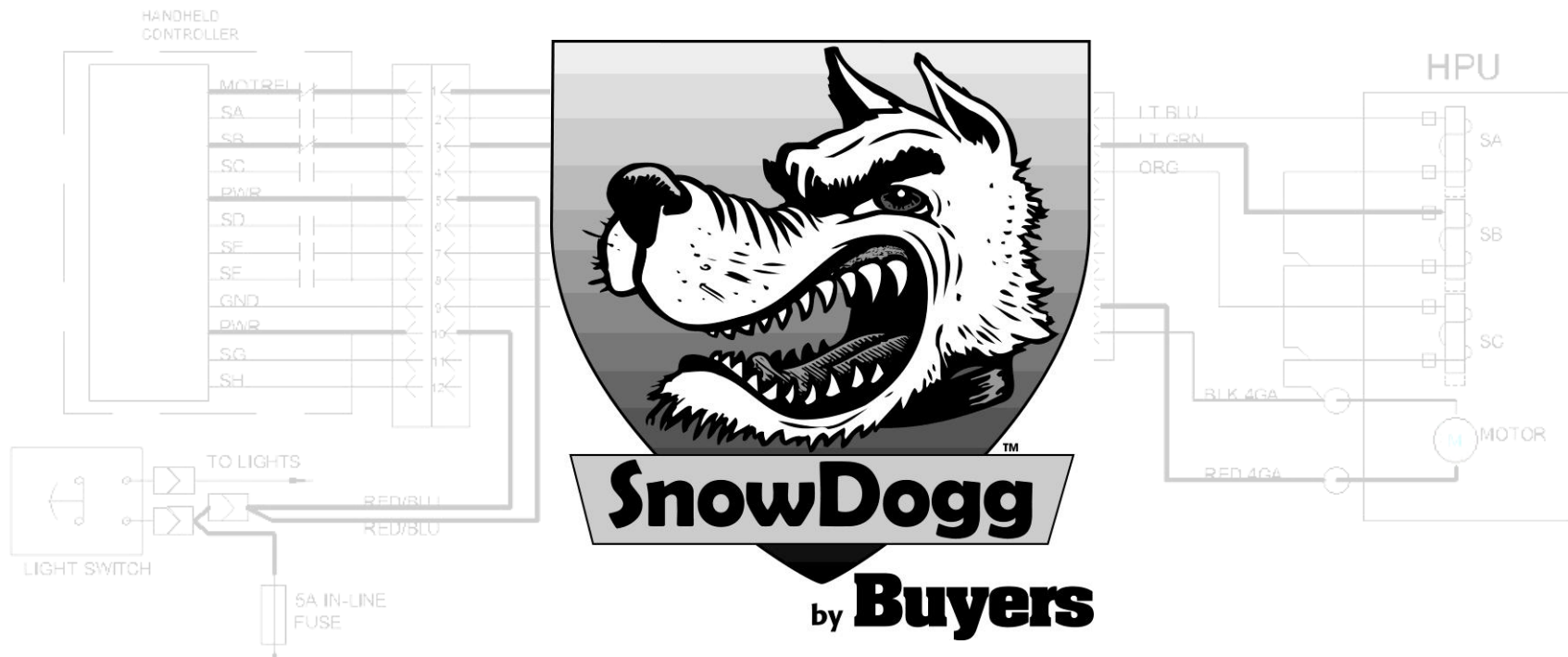

LEGEND

Shown is the snowplow with NO valves energized – all cylinders are locked. These simplified representations show the actual state of the valves to aid in understanding the circuit. Standard colors are used to represent the circuit in various states. Arrows have been added to depict the direction of oil flow and cylinder movement.

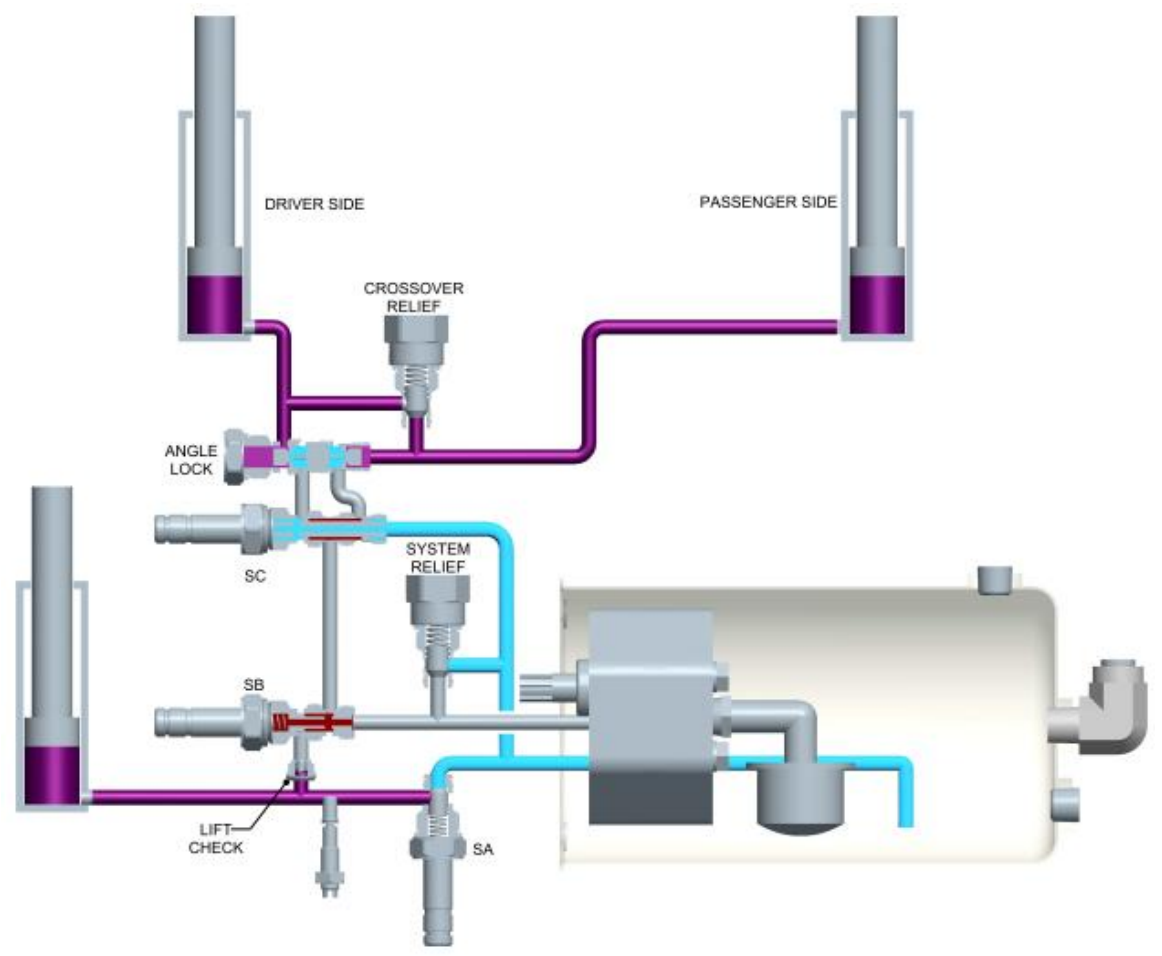
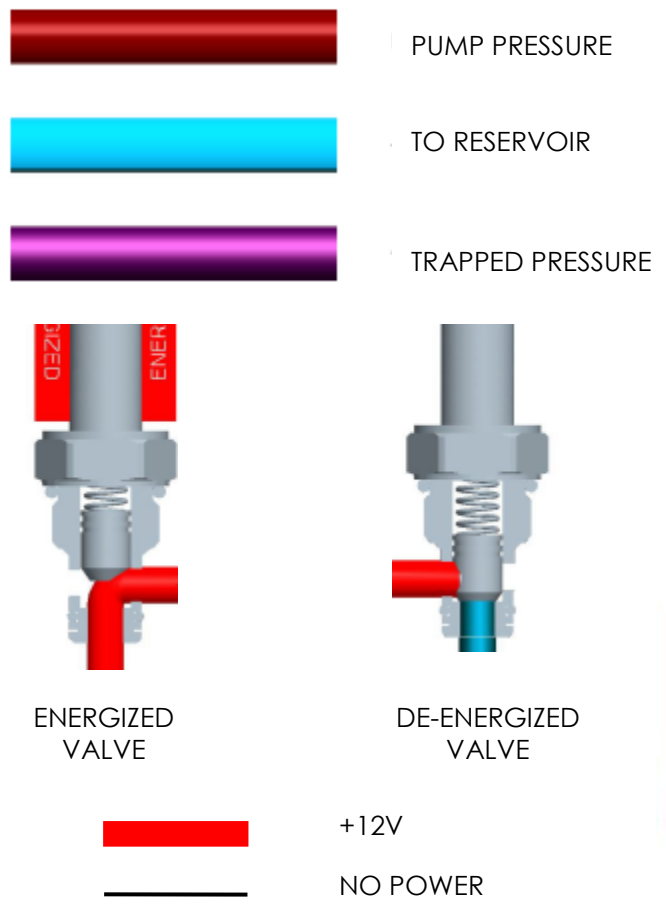

SCHEMATIC REFERENCE

LIFT

When the LIFT button is pressed, the MOTOR and VALVE SB are energized and fluid from the pump is diverted by VALVE SB through the CHECK VALVE and into the lift cylinder. VALVE SA remains closed, preventing the lift cylinder from retracting.

If the cylinder reaches end of stroke or the lift cylinder is blocked while the LIFT button is pressed, oil goes through the PUMP RELIEF to the reservoir. The controller will shut off after 10 seconds to protect the motor. When the LIFT button is released, the MOTOR and VALVE SB de-energize. The CHECK VALVE and VALVE SA block return flow, keeping the lift cylinder locked in position.

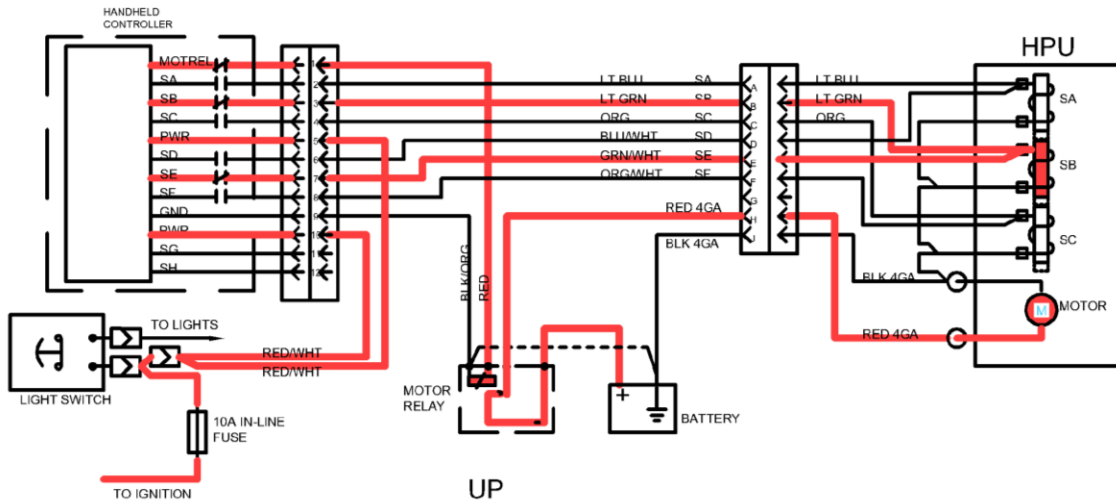
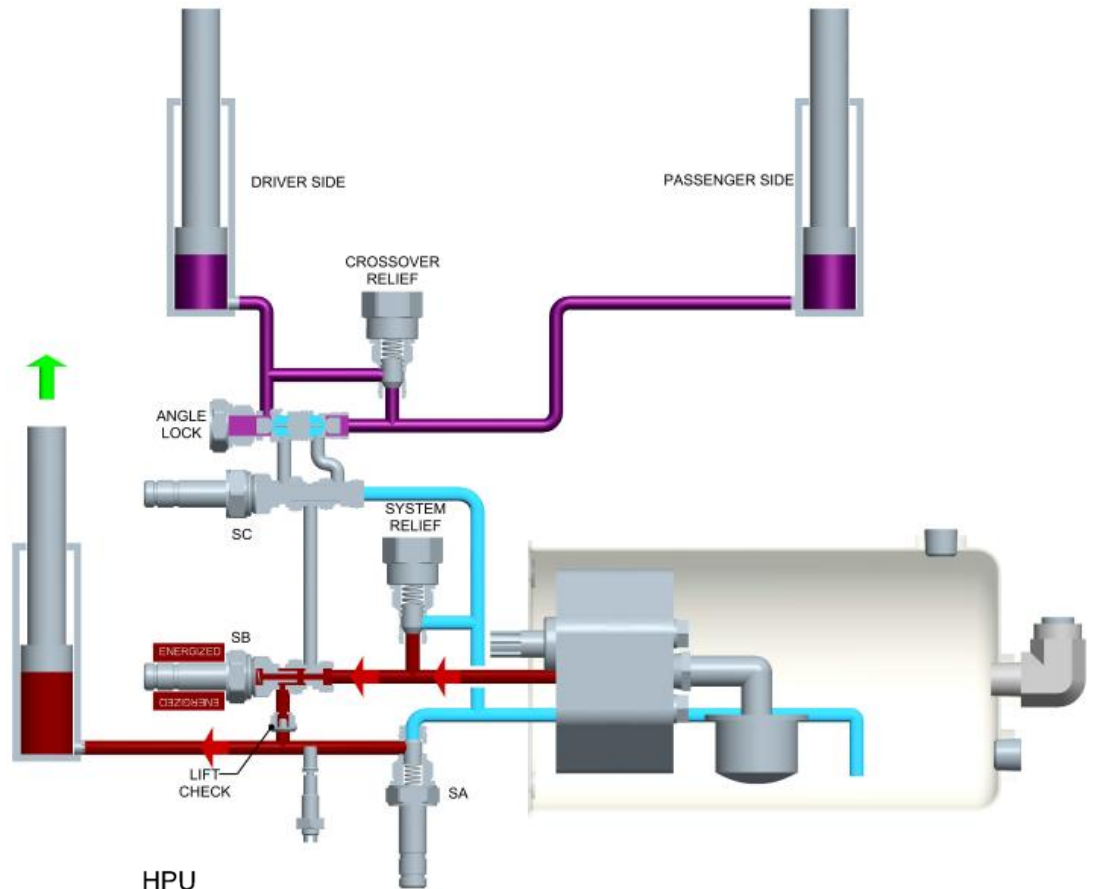

LOGIC TABLE				
	MOTOR	SA	SB	SC
LIFT	1	-	1	-
LOWER	-	1	-	-
FLOAT	-	1	-	-

LOWER/FLOAT

When the LOWER button is pressed, valve SA is energized and fluid from the lift cylinder is drained to tank through valve SA and the LOWERING NEEDLE to the reservoir.

If the LOWER button is held for more than one second, the controller goes into FLOAT mode and lights the FLT indicator. In this mode, valve SA remains energized allowing the chain to go slack and for the moldboard to follow the ground.

If the LOWER button is released prior to FLOAT mode being activated, valve SA de-energizes. The check valve and valve SA block return flow from the cylinder, keeping the lift cylinder locked in position.

FLOAT mode is deactivated immediately by pressing the LIFT button. The plow may be angled while in FLOAT mode.

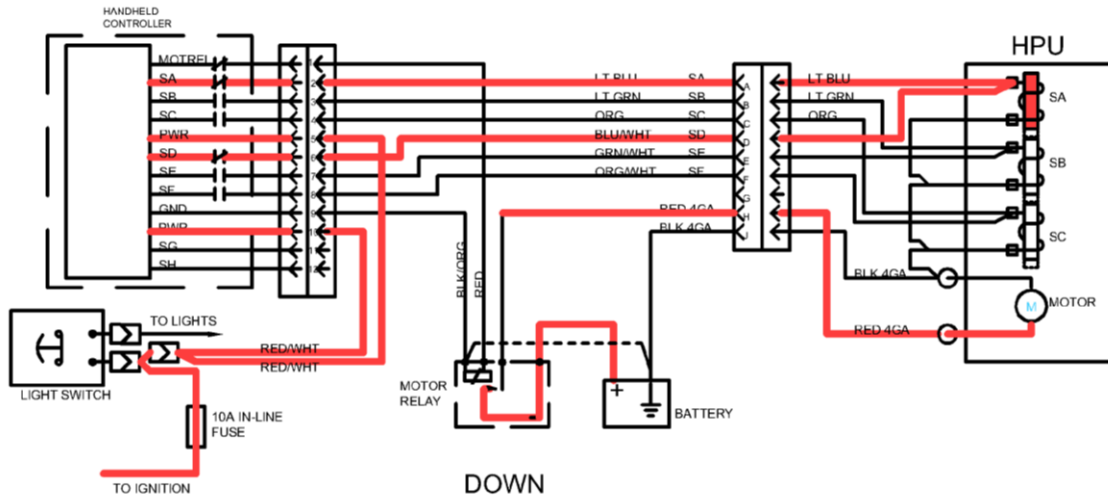
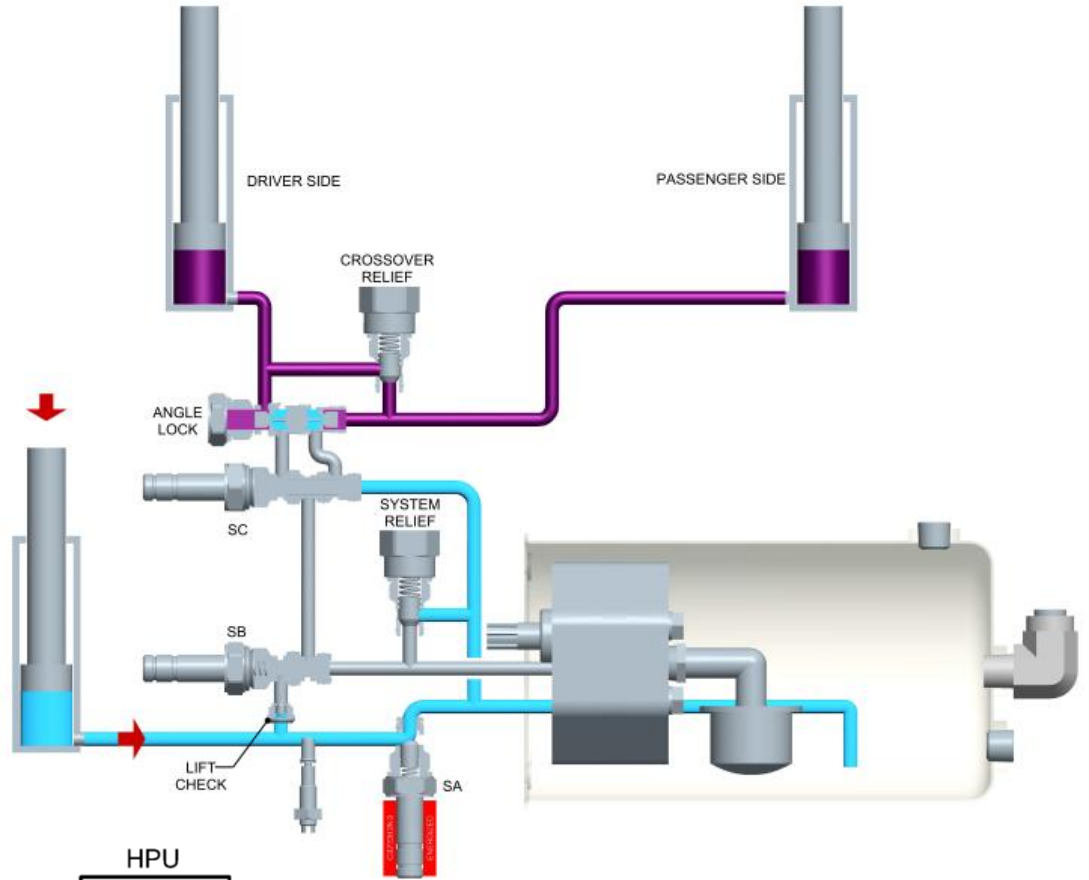

LOGIC TABLE				
	MOTOR	SA	SB	SC
LIFT	1	-	1	-
LOWER	-	1	-	-
FLOAT	-	1	-	-
LEFT	1	-	-	-
RIGHT	1	-	-	1

SCHEMATIC REFERENCE

LEFT

When the LEFT button is pressed, the MOTOR is energized and fluid goes through valves SB, SC and ANGLE LOCK valve to the LEFT cylinder. As the LEFT cylinder extends, the RIGHT cylinder retracts, sending fluid back through the ANGLE LOCK valve (held open by pressure from the pump) and valve SC to tank.

If the cylinder reaches end of stroke or the LEFT or RIGHT cylinder are blocked while the LEFT button is pressed, oil goes through the PUMP RELIEF to the reservoir. The controller will shut off after 10 seconds to protect the motor.

When the LEFT button is released, the motor de-energizes and the LEFT and RIGHT cylinders are locked in position by the ANGLE LOCK valve.

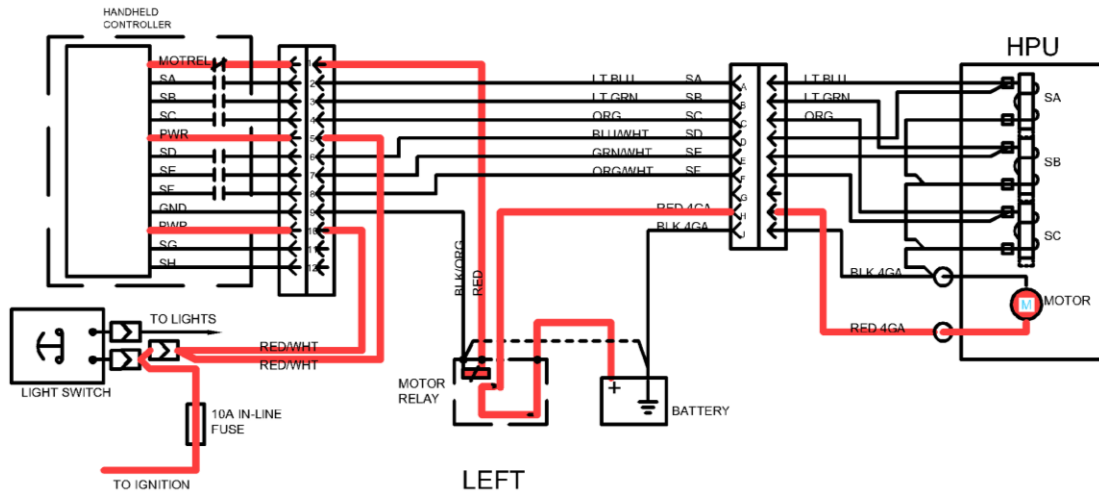
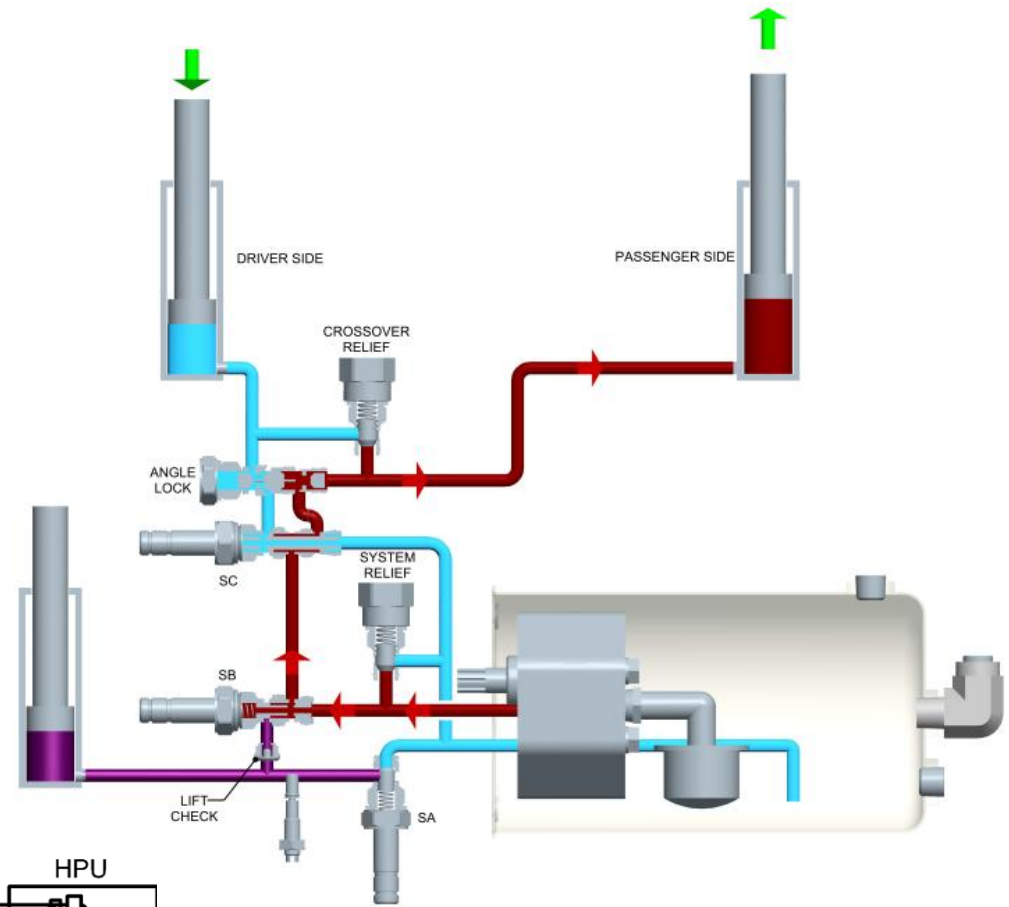

LOGIC TABLE				
	MOTOR	SA	SB	SC
LIFT	1	-	1	-
LOWER	-	1	-	-
FLOAT	-	1	-	-
LEFT	1	-	-	-
RIGHT	1	-	-	1

SCHEMATIC REFERENCE

RIGHT

When the RIGHT button is pressed, the MOTOR and valve SC are energized and fluid goes through valves SB, SC and the ANGLE LOCK valve to the RIGHT cylinder. As the RIGHT cylinder extends, the LEFT cylinder retracts, sending fluid back through the ANGLE LOCK valve (held open by pressure from the pump) and valve SC to tank.

If the cylinder reaches end of stroke or the LEFT or RIGHT cylinder are blocked while the RIGHT button is pressed, oil goes through the PUMP RELIEF to the reservoir. The controller will shut off after 10 seconds to protect the motor.

When the RIGHT button is released, the motor and valve SC de-energize and the LEFT and RIGHT cylinders are locked in position by the ANGLE LOCK valve.

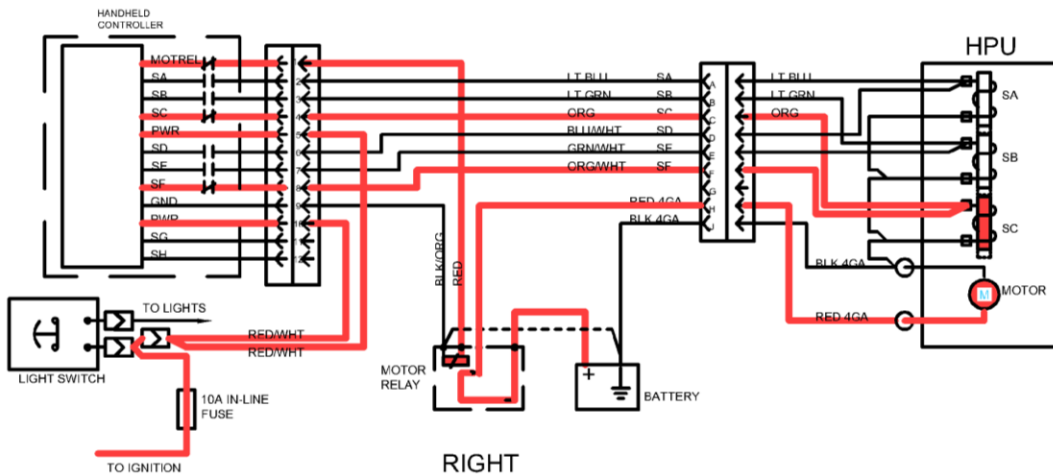
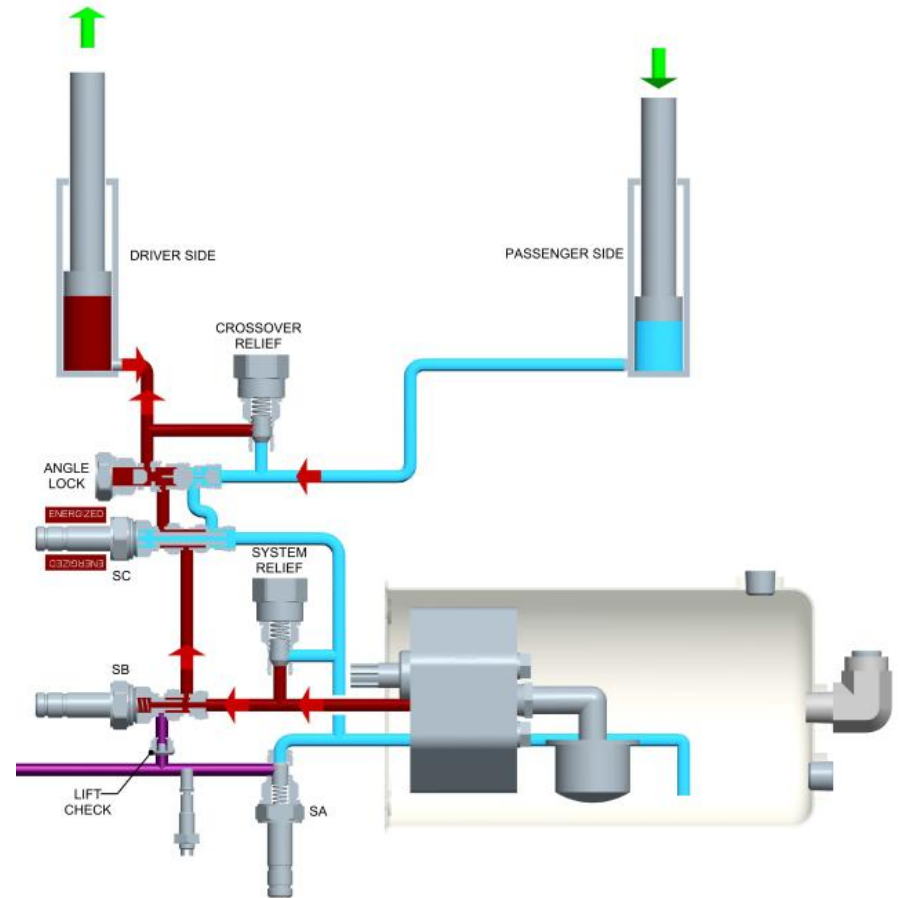

LOGIC TABLE				
	MOTOR	SA	SB	SC
LIFT	1	-	1	-
LOWER	-	1	-	-
FLOAT	-	1	-	-
LEFT	1	-	-	-
RIGHT	1	-	-	1

NOTES

